

HURRICANE POWER

Commercial Debris Blower

X3 Parts Manual

S/N 171081 - 171224

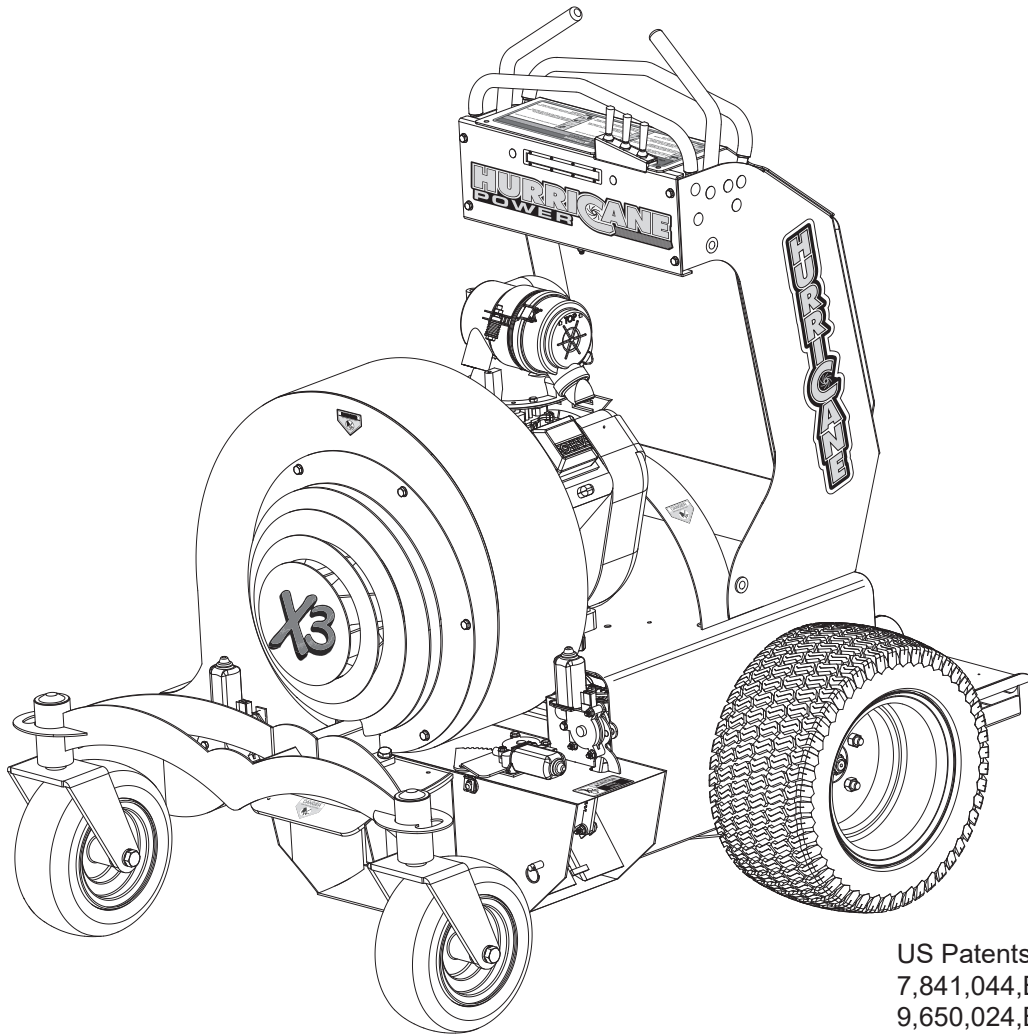

US Patents
7,841,044,B1
9,650,024,B2

DECALS

Decals

Hurricane Power

	Part Number	Description	Quantity		Part Number	Description	Quantity
1	425-4201	Front Logo Decal	1	8	425-4209	Hydro Decal	1
2	X3-4212	Data Plate	1	9	425-4206	Danger Decal	5
3	X3-4210	Top Dash Decal	1	10	425-4204	Made in the USA Decal	1
4	425-4205	Hot Decal	1	11	425-4211	Dash Controls Decal	1
5	425-4202	Left Logo Decal	1	12	314-17-42100	Trans Bypass	2
	425-4203	Right Logo Decal	1	13	X3-4213	Emergency Brake Release	1
6	X3	Safety Cover Decal	1	14	X3-16-4202	Left/Right Upright Decal	2
7	425-4208	Pinch Decal	2	15	X3-16-4201	Front Logo Decal	1

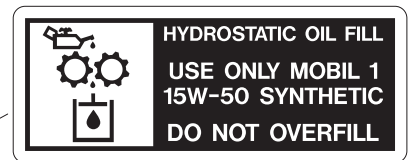
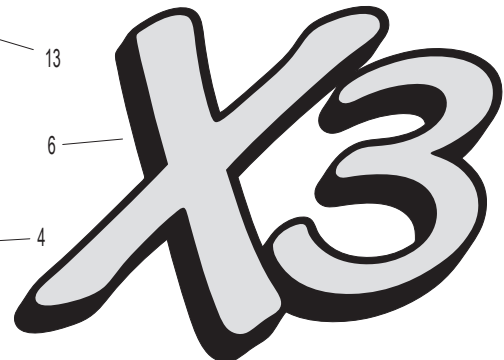
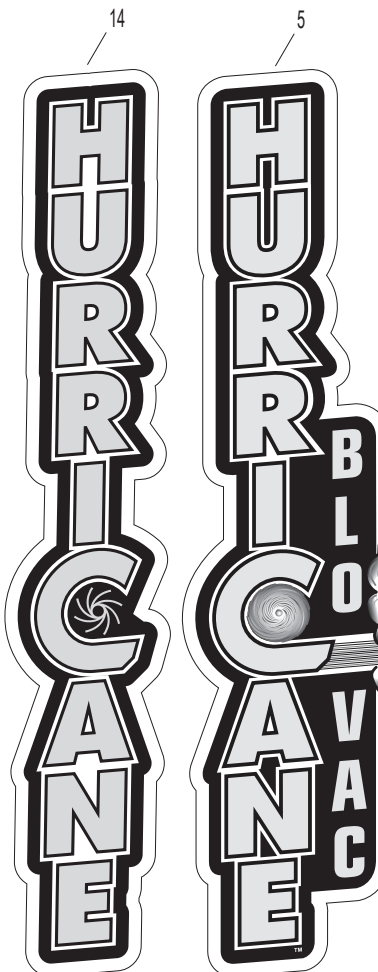
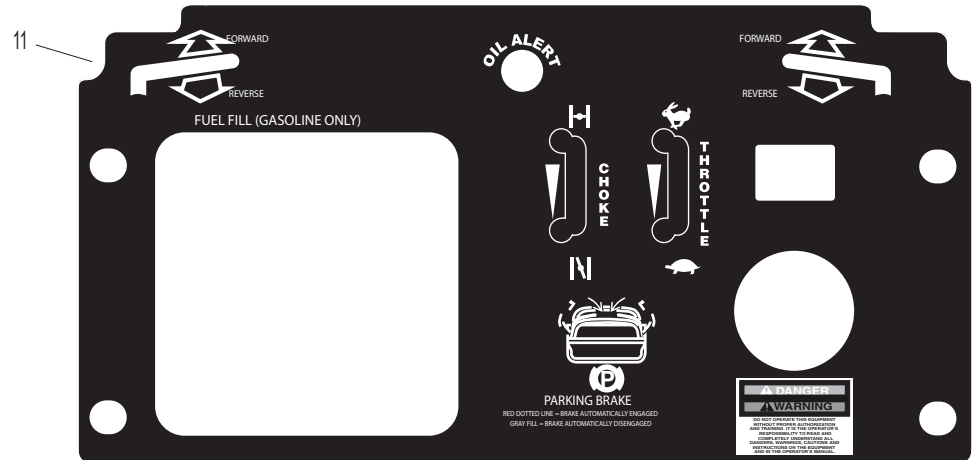
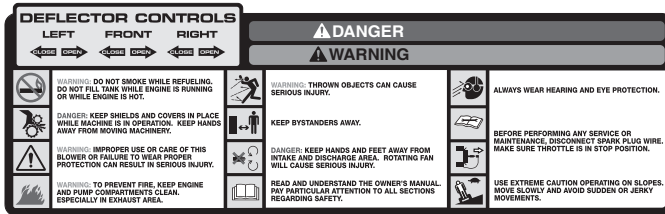
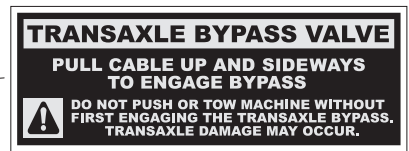

CHASSIS COMPONENTS

Chassis

Hurricane Power

Part Number	Description	Quantity	Part Number	Description	Quantity		
1	X3-1452	Dash	1	32	15153	Bolt 5/8-11 x 6-1/2	2
2	15102	1/4-20 x 3/4 Flange Bolt	10	33	109-10-2010	Caster Fork	2
3	15101	1/4-20 Flange Nut	12		109-10-T2010	Caster Fork	2*
4	ZF1751	Dash Front Panel	1	34	XF17029	Front End Frame Assembly	1
	ZFT1751	Dash Front Panel	1*		XFT17029	Front End Frame Assembly	1*
5	15108	5/16-18 x 3/4 Flange Bolt	6	35	0117-162024	Plastic Bushing	4
6	112-18-1812	Pad	1	36	15137	3/4 Machine Bushing	2
7	15112	3/8-16 x 3/4 Flange Bolt	28	37	X3-14-3017	Hydro 90° Bracket	2
8	15109	5/16-18 x 3/4 Carriage Bolt	12	38	XF1750	Rear Chassis Frame	1
9	XF1733	Left Upright	1	39	X3-1444	Toe Kick	1
	XFT1733	Left Upright	1*		X3-T1444	Toe Kick	1*
10	15107	5/16-18 Flange Nut	18	40	15062	3/8-16 x 1 Flange Bolt	14
11	15111	3/8-16 Flange Nut	66	41	16-2002	Front End Torsion Plate	1
12	16-2003	Rubber Cord (Set of 4)	1	42	15157	5/16-18 x 1/2 Self Tapping Screw	2
13	15061	1/4-20 Riv-Nut	2				
14	X310-2006	Right Side Plate Tie Down	1	43	XF1743	Bottom Chassis Bracket Left	1
	X310-T2006	Right Side Plate Tie Down	1*	44	XF1730	Hydro I-Beam	1
15	X310-2018	Left Side Plate Tie Down	1	45	XFT1720	Belt Guard	1
	X310-T2018	Left Side Plate Tie Down	1*	46	ZP16225	5/16-18 x 2-1/4 Flange Hex Bolt	4
16	15056	1/2-13 Nylock Jamb Nut	1				
17	16-30502	Reverse Stop	1	47	X3-1440	Neutral Centering Bracket	2
	16-T30502	Reverse Stop	1*				
18	425-16-11100	Rubber Mount	4	48	X3-1454	Battery Door	1
19	X310-2011	Foot Pad	1		X3-T1454	Battery Door	1*
20	XF1753	Upper I-Beam Mount	2	49	X3-1455	Motor Box Spacer	2
21	XF1749	Front Chassis Frame	1	50	15313	1/4-20 x 1/2 Cap Screw With Plastic Knob	1
22	16-30501	Forward Stop	1				
	16-T30501	Forward Stop	1*	51	5187	Rubber Grommet	2
23	X3-1447	Right Upright	1	52	ZF17042	Relay Mount Bracket	1
	XFT1732	Right Upright	1*	53	XF1740	Bottom Chassis Bracket Right	1
24	XF17007	Motor Box	1				
	XFT17007	Motor Box	1*	54	ZF1445	Debris Guard	1
25	X3-1445	Skid Plate	1	55	ZF1745	Forward Debris Guard	1
26	15136	1 x 10 Gauge Machine Bushing	4	56	ZF17403	"L" Headlight Bracket	2
				57	17109	1/4-20 x 3/4 Carriage Bolt	4
27	15161	Plastic Grease Cap	2	58	15064	1/2-13 x 1-1/4 Flange Bolt	4
28	15139	3/4-10 Nylon Jamb Nut	2	59	15046	1/2-13 Flange Nut	4
29	15581	5/8-11 Nylock Nut	2	60	17107	5/16-18 Serrated Flange Nut	4
30	109-17-7011	Caster Bearings	4				
31	109-17-7012	Caster Wheel & Tire with Bearing	2				

* Please note the powder coat change. Serial Number 171102 and higher have textured powder coat.

FUEL AND THROTTLE COMPONENTS

	Part Number	Description	Quantity		Part Number	Description	Quantity
1	1101-73601	Fuel Cap	1	11	425-1041-76010	Throttle/Choke Cable	2
2	ZF15034	Fuel Tank	1	12	110-17-5407	1/4 x 3/16 Reducer	1
3	15091	1/4-20 x 3/4 FPHMS	4	13	110-17-5406	1/4 Tee	1
4	15101	1/4-20 Flange Nut	4	14	110-17-5403	Fuel Filter	1
5	N/A	Zipties	14	15	X3-TL522	Plastic Elbow	1
6	ZP15039	Fuel Line (6")	4	16	ZP15036	Fuel Line (2-1/2")	2
7	1101-73805	Ball Valve Fuel Shutoff	1	17	110-17-5404	Emissions Filter	1
8	ZP15054	Fuel Line (5")	1	18	110-17-5405	Check Valve	1
9	1101-73811	Fuel Pickup	1	19	ZP15038	Fuel Line (4")	1
10	XP15090	Phillips, Self Drilling	4				

HYDROSTATIC COMPONENTS

Hydro

Hurricane Power

Part Number	Description	Quantity	Part Number	Description	Quantity		
1	139530	Control Grip 9-1/2"	2	31	15060	1/2 x 2-1/2 Clevis Pin	2
2	15162	3/32" Cotter Pin	4	32	16127	#98 Idler Spring	1
3	14-40-2011	Control Handle	2	33	15303	1/2-13 x 2 Hex Bolt	2
4	15140	1/4-28 Nylock Nut	4	34	17-4101	Idler Pulley	1
5	15315	1/2 x 4-1/2 Clevis Pin	2	35	425-52114	Hydro Oil Filter	2
6	0117-081216	Plastic Bushings	8	36	15046	1/2-13 Flange Nut	1
7	X3-1437	Lower Control Switch	1	37	ZF15052	Idler Arm	1
		Bracket Right		38	15101	1/4-20 Flange Nut	8
8	X3-1438	Lower Control Switch	1	39	15047	1/2-13 Nylock Nut	1
		Bracket Left		40	XP173213	1/4-20 x 1/2 Set Screw	2
9	15081	1/4-28 Right Hand Nut	2	41	15054	1/4 x 1-1/4 Key Stock	1
10	2500-2100	1/4-28 x 21" Rod	2	42	XF17-3211	Drive Pulley	1
11	15086	1/4-28 Left Hand Nut	2	43	XP-A4545	Drive Belt	1
12	103-17-4635	1/4-28 x 3" Turnbuckle	2	44	XP17020	Engine - Vanguard 23 HP	1
13	ZP16054	4-1/2" Control Rod	2	45	HU002	Hydro Fitting	2
14	106-17-4637	1/4-28 Ball Joint LH	2	46	103-17-4633	1/4-28 Right Hand	2
15	X3-1520	Transmission Control Arm	2			90 Knuckle	
16	15107	5/16-18 Flange Nut	8	47	XP17013	X3 Muffler Kit	1
17	17444	5/16-24 x 1-1/2" Bolt	4	48	XP17012	Muffler Clamp	1
18	103-17-4429	Ball Stud	4	49	X3-72123ZT	Fan Pulley Kit	2
19	103-17-4431	Dampener Clip	4	50	3A7C-1XXX	Right Hydro Pump - X	1
20	425-103-174430	Dampener	2	51	3A7B-1XXX	Left Hydro Pump - X	1
21	ZF15048	Hydro Tank Bracket	1	52	X3-14-7012	20 x 8 x 8 Drive	2
22	15102	1/4-20 x 3/4 Flange Bolt	8			Tire and Rim	
23	ZP15047	Hydro Tank	2	53	15088	1/2-20 Lug Nut	8
24	15083	Oetiker Clamp	4	54	XF1744	Thin Spacer Plate	1
25	X3-16050	Hydro Hose	2	55	XF1745	Thick Spacer Plate	2
26	X3-14-14	Hydro Neutral Release	2	56	314-15-15147	5/16" Flat Washer	4
		Cable		57	15082	5/16" Lockwasher	4
27	15111	3/8-16 Flange Nut	13	58	15109	5/16-18 x 3/4" Carriage Bolt	2
28	15087	3/8-16 x 2-1/2 Flange Bolt	8	59	15112	3/8-16 x 3/4" Flange Bolt	2
29	15072	3/8-16 x 9-1/2 Hex Bolt	1	60	ZP15018	Oil Drain	1
30	X3-1436	Hydro Spacer Tube	1				

BRAKE ASSEMBLIES

Brakes

Hurricane Power

	Part Number	Description	Quantity		Part Number	Description	Quantity
1	15306	1/4-20 x 2 Phillips Head Machine	1	11	X3-1511	Brake Backing Plate	1
2	15307	1/4-20 x 2 Hex Bolt	1	12	X3-1512	Brake Cam	1
3	15128	#29 Extension Spring	1	13	X3-1513	Brake Spacer Bar	1
4	15308	#21 Compression Spring	1	14	X3-1514	Cam Cover Plate	1
5	15309	#29 Compression Spring	1	15	ZF15053	Brake Release Lever	1
6	15165	1/4-20 x 1-3/4 Phillips Head Machine Screw	2	16	X3-1516	Brake Gear Rack	1
7	15101	1/4-20 Flange Nut	5	17	X3-1517	Brake Lever Arm	1
8	15067	1/4-20 Nylock Nut	2	18	X3-1518	Switch Mounting Plate	1
9	15016	1/4-20 Flat Washer	3	19	X3-1519	Hydro Brake Arm	2
10	15310	5/16 x 1/2 Shoulder Bolt	1	20	15102	1/4-20 x 3/4 Flange Bolt	3
				21	153101	5/16 x 1-1/4 Shoulder Bolt	2

BRAKE ASSEMBLIES

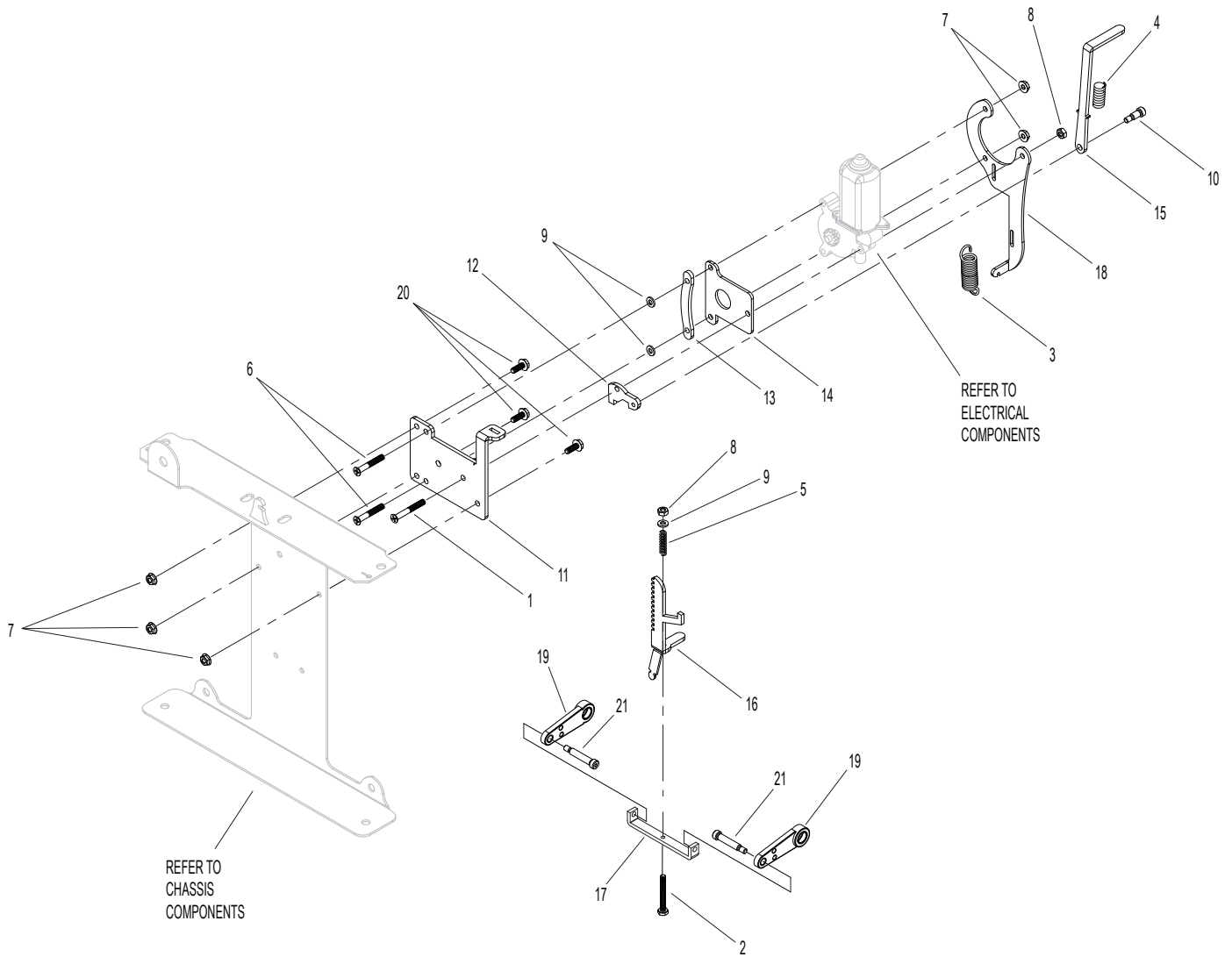

BLOWER COMPONENTS

Blower

Hurricane Power

Part Number	Description	Quantity	Part Number	Description	Quantity		
1	XF1724	Right Deflector Cover Plate	1	21	XF1766	Deflector Support Rod	1
2	XF17015	Safety Cover	1	22	15080	1/4" Lock Washer	4
	XFT17015	Safety Cover	1*	23	15165	1/4-20 x 1-3/4	4
3	15108	5/16-18 x 3/4 Flange Bolt	6			Phillips Head Screw	
4	X310-2036	Motor Spacer	3	24	XF1739	Right Deflector Gear	1
5	15225 or 15164	Deflector Cover Spacer	4	25	X310-2052	Deflector Spacer Plate	2
6	17092	7/16-20 x 2 Hex Bolt	1	26	101-10-2028	Rack Keeper	1
7	17009	7/16 ID x 1-3/4 OD	1	27	15102	1/4-20 Flange Bolt	3
		Impeller Washer		28	X310-2044	Forward Deflector Pin	2
8	XF1737	1-1/8" Crankshaft	1	29	XF1741	Right Deflector	1
		Impeller		30	X310-2042	Forward Deflector Gear	1
9	XF17006	Blower Housing	1	31	X310-2043	Forward Deflector	1
	XFT17006	Blower Housing	1*			Motor Mount	
10	15098-1	5/8 Lockwasher	1	32	ZF15158	Deflector Lock Pin	1
11	17110	5/16-24 x 2" Set Screw	4			Retaining Cable	
12	15104	1/4-20 x 1-1/4 Phillips	4	33	XF1742	Forward Deflector	1
		Head Screw		34	XF1746	Left Power Deflector	1
13	101-16-2029	Rack Spacer	1	35	XF1747	Left Slave Deflector	1
14	15158	Deflector Lock Pin	1	36	17052	3/8 x 2-3/4 Key Stock	1
15	15101	1/4-20 Flange Nut	15	37	16102	1/4-20 x 1-1/4 Flange Bolt	3
16	101-17-6427	Safety Clip	2	38	XP17110	5/16-24 Serrated Nut	4
17	0117-081216	1/2 Plastic Bushing	8				
18	101-16-1821	Deflector Rack	1				
19	15124	1/2 SAE Washer	2				
20	15103	1/4-20 x 1-1/2 Flange Bolt	1				

* Please note the powder coat change. Serial Number 171102 and higher have textured powder coat.

BLOWER COMPONENTS

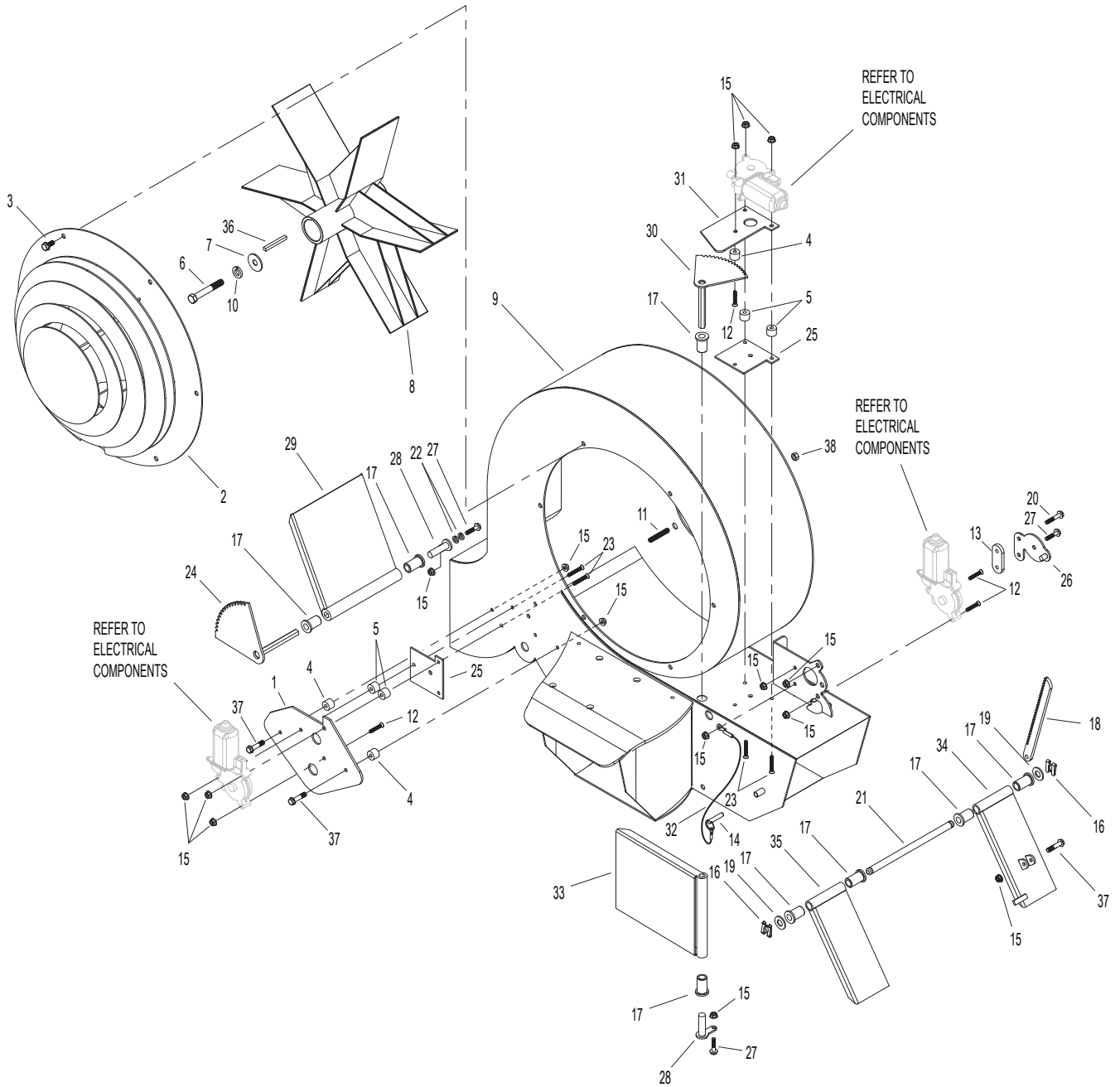

ELECTRICAL COMPONENTS

Electrical

Hurricane Power

Part Number	Description	Quantity	Part Number	Description	Quantity		
1	106-17-4001	U1 Battery	1	13	104-17-2805	Warning Light	1
2	X3-18-1802	Positive Battery Cable	1	14	106-17-2817	Relay	3
3	X3-18-1803	Negative Battery Cable	1	15	18272	Switch Extension (Yellow)	1
4	104-17-5205	Tach	1	16	101-18-1802	Deflector Motor Left	1
	106-18-1804	Tach Harness	1	17	ZF1750	Headlight	1
5	106-17-3005	Switch Extension (Red)	1	18	XP15884	Main Wiring Harness	1
6	106-17-2806	Switch Seal	3	19	15106	10-32 Keps Nut	12
7	106-17-3007	Reversing Switch	3	20	15107	5/16-18 Flange Nut	2
8	104-17-5610	Ignition Switch (Snap In)	1	21	15105	10-32 Machine Screw	12
9	X3-4090	Safety Switch (1 PR)	1	22	15108	5/16-18 x 3/4 Flange Bolt	2
10	104-17-5608	Ignition Switch Key	1	23	18273	Switch Extension (Black)	1
11	101-17-5612	Safety Switch 2P	3	24	314-0618-255R	Deflector Motor Right	3
12	16100	Battery Strap	1				

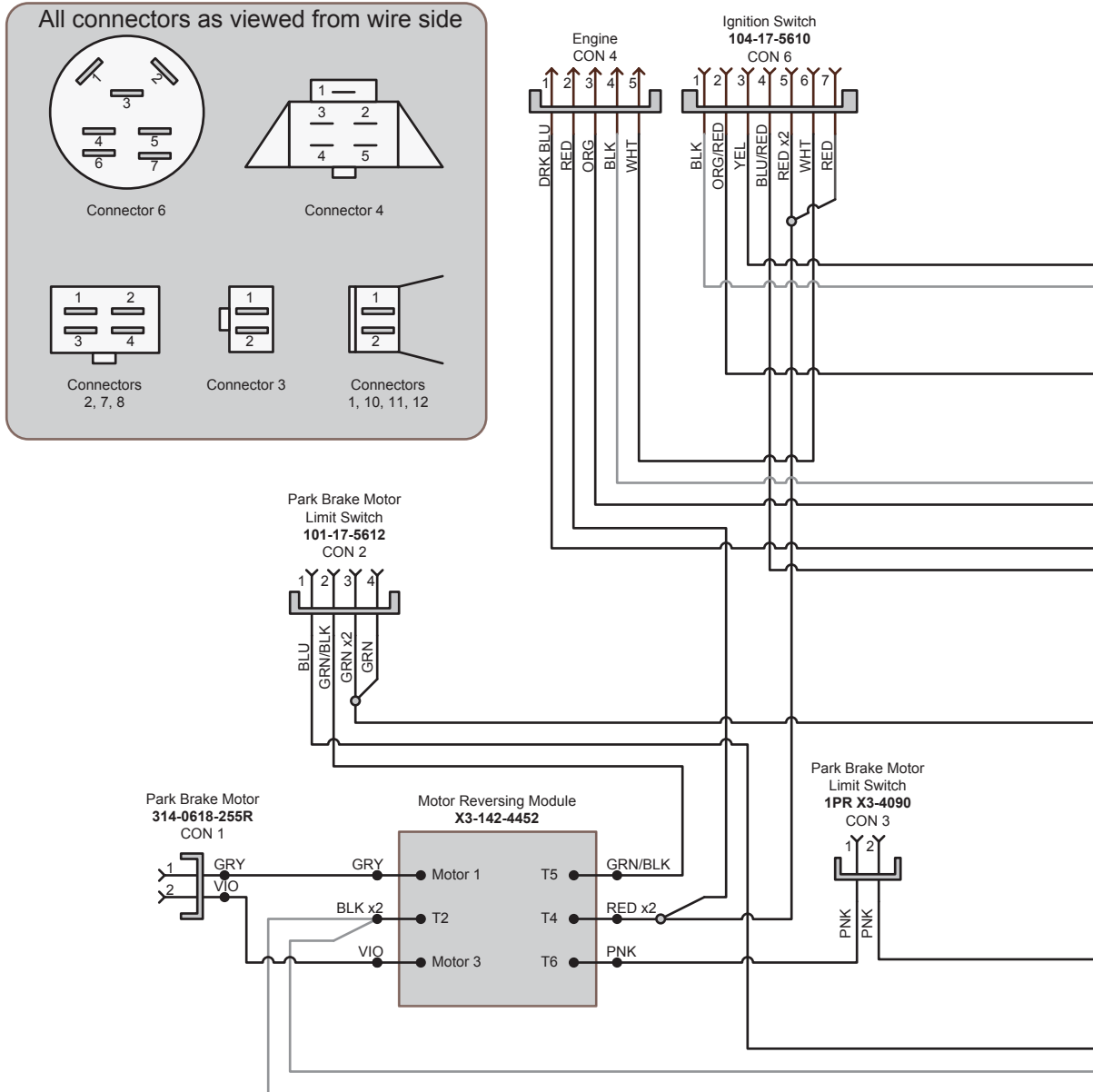

Rev: 07/01/2014

ELECTRICAL SCHEMATIC

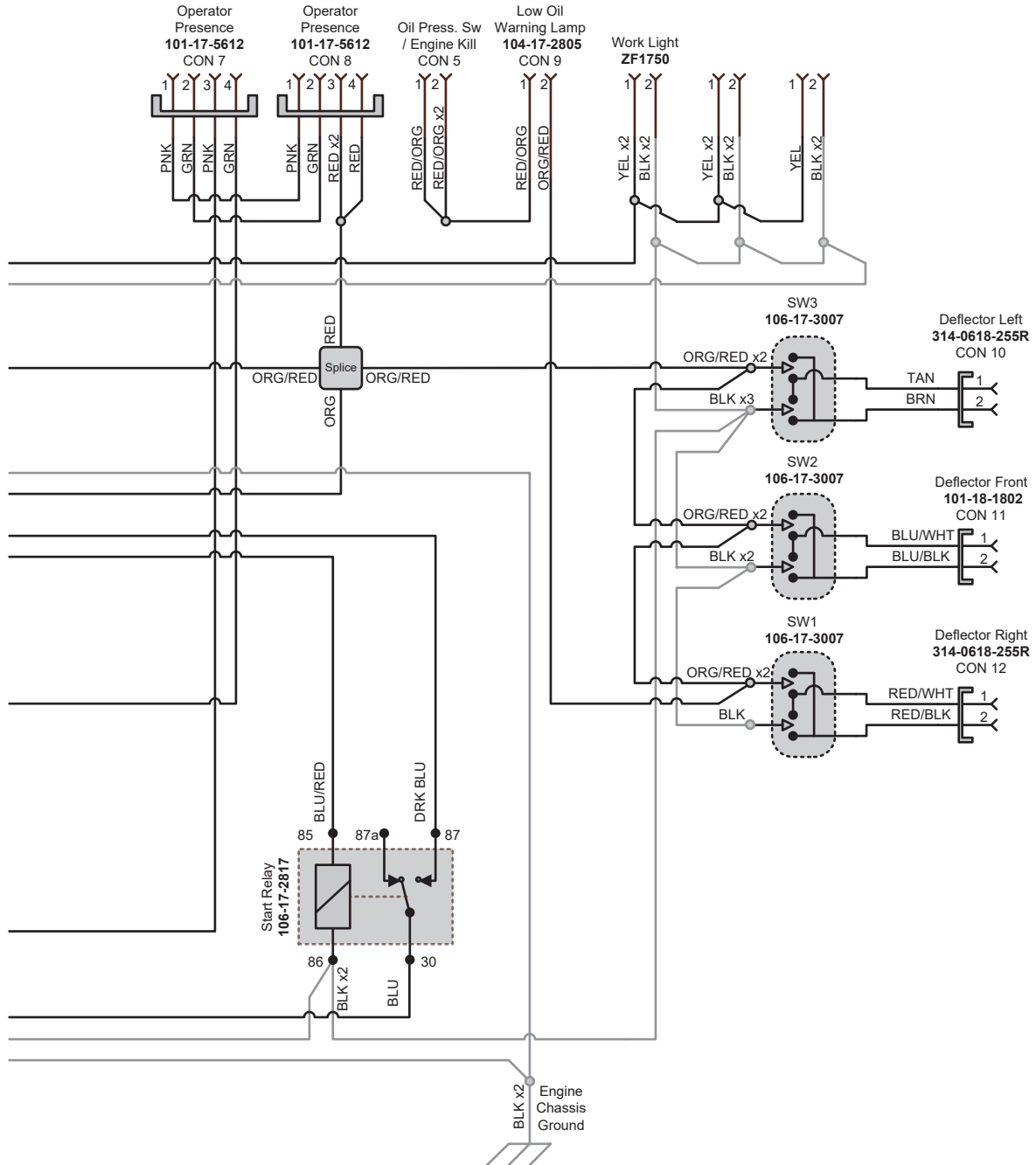

Muskegon, MI