

2 REPLACEMENT PARTS

FLAIL BLADES

P/N 350186.

A complete replacement set. 52 of our high quality flail blades for your PR. Includes 8 new lock clips for replacement installation.

FLAIL SHAFTS

P/N 350185.

A full set of four shafts for replacement. Includes 8 new lock clips for replacement installation.

Note: We recommend replacing the shafts when you replace flails.

DRIVE BELT

P/N 350116.

Original Equipment drive belt for your PR.

SPACER BUMPERS

P/N 350258.

A complete replacement set. 44 of 1/2" spacer bumpers and 4 of 1/4" spacer bumpers

ACCESSORIES

SLICING REEL

P/N 350113.

A complete verti-slicing reel for your PR. 20" wide reel for use in grasses that require vertical cutting, and for assisting in lawn overseeding projects.

SLICING BLADES

P/N 350187.

A full set of twenty blades for replacement. Includes 40 new capscrews, and lock nuts for replacement installation.

OVERSEEDER KIT

P/N 350325 / 350328.

The new light weight Plastic Overseeding Kit is constructed of durable High Density Polypropylene with two lift handles on each side to assist in lifting the entire unit and easily converts a PR Series Power Rake into an overseeder with 4 bolts and minimal tools.

NOTE: Overseeder Conversion Kit (350328) includes Slicing Reel (350113). Part No. (350325) comes with the Overseeder Box only.

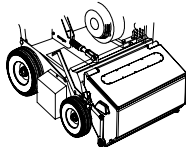

NEW

1

BILLY GOAT 

CE



*Thank You for Selecting
The Powerful PR and OS
POWER RAKES and OVERSEEDERS*

Operator Owner's Manual

**PR550, PR550H, PR550V,
PR550HV, OS551, OS551H**

3

Specifications

	PR550	PR550V	PR550H	PR550HV	OS551	OS551H
ENGINE H.P.	5.5 (4.1 kW)	5.5 (4.1 kW)	5.5 (4.1 kW)	5.5 (4.1 kW)	5.5 (4.1 kW)	5.5 (4.1 kW)
ENGINE TYPE	B&S OHV	B&S OHV	HONDA OHV	HONDA OHV	B&S OHV	HONDA OHV
ENGINE FUEL CAP.	3.0 qt. (2.84 L)	3.0 qt. (2.84 L)	3.88 qt. (3.6 L)	3.88 qt. (3.6 L)	3.0 qt. (2.84 L)	3.88 qt. (3.6 L)
ENGINE OIL CAP.	0.66 qt. (0.62 L)	0.66 qt. (0.62 L)	0.69 qt. (0.65 L)	0.69 qt. (0.65 L)	0.66 qt. (0.62 L)	0.69 qt. (0.65 L)
WEIGHT: UNIT	160# (72.5 kg)	163# (74.1 kg)	158# (71.8 kg)	161# (73.2 kg)	173# (78.5 kg)	171# (77.6 kg)
WEIGHT: SHIPPING	183# (83.0 kg)	183# (83.0 kg)	178# (80.9 kg)	178# (80.9 kg)	208# (94.3 kg)	209# (94.8 kg)
ENGINE WEIGHT:	36# (16.3 kg)	36# (16.3 kg)	34# (15.4 kg)	34# (15.4 kg)	36# (16.3 kg)	34# (15.4 kg)
MAX. ENGINE OPERATING SLOPE	15°	15°	20°	20°	15°	20°

5

IN THE INTEREST OF SAFETY



BEFORE STARTING ENGINE, READ AND UNDERSTAND THE "ENTIRE OPERATOR'S MANUAL & ENGINE MANUAL."



THIS SYMBOL MEANS WARNING OR CAUTION. DEATH, PERSONAL INJURY AND/OR PROPERTY DAMAGE MAY OCCUR UNLESS INSTRUCTIONS ARE FOLLOWED CAREFULLY.



WARNING: The Engine Exhaust from this product contains chemicals known to the State of California to cause cancer, birth defects or other reproductive harm.

WARNING: DO NOT

1. **DO NOT** run engine in an enclosed area. Exhaust gases contain carbon monoxide, an odorless and deadly poison.

2. **DO NOT** place hands or feet near moving or rotating parts.

3. **DO NOT** store, spill or use gasoline near an open flame, or devices such as a stove, furnace, or water heater which use a pilot light or devices which can create a spark.

4. **DO NOT** refuel indoors where area is not well ventilated. Outdoor refueling is recommended.

5. **DO NOT** fill fuel tank while engine is running. Allow engine to cool for 2 minutes before refueling. Store fuel in approved safety containers.

6. **DO NOT** remove fuel tank cap while engine is running.

7. **DO NOT** operate engine when smell of gasoline is present or other explosive conditions exist.

8. **DO NOT** operate engine if gasoline is spilled. Move machine away from the spill and avoid creating any ignition until the gasoline has evaporated.

9. **DO NOT** transport unit with fuel in tank.

10. **DO NOT** smoke when filling fuel tank.

11. **DO NOT** choke carburetor to stop engine. Whenever possible, gradually reduce engine speed before stopping.

12. **DO NOT** run engine at excessive speeds. This may result in injury & /or damage to unit.

13. **DO NOT** tamper with governor springs, governor links or other parts which may change the governed engine speed.

14. **DO NOT** tamper with the engine speed selected by the engine manufacturer.

15. **DO NOT** check for spark with spark plug or spark plug wire removed. Use an approved tester.

16. **DO NOT** crank engine with spark plug removed. If engine is flooded, place throttle in "FAST" position and crank until engine starts.

17. **DO NOT** strike flywheel with a hard object or metal tool as this may cause flywheel to shatter in operation. Use proper tools to service engine.

18. **DO NOT** operate engine without a muffler. Inspect periodically and replace, if necessary. If engine is equipped with muffler deflector, inspect periodically and replace, if necessary, with correct deflector.

19. **DO NOT** operate engine with an accumulation of grass, leaves, dirt or other combustible material in the muffler area.

20. **DO NOT** use this engine on any forest covered, brush covered, or grass covered unimproved land unless a spark arrester is installed on the muffler. The arrester must be maintained in effective working order by the operator. In the State of California the above is required by law (Section 4442 of the California Public Resources Code). Other states may have similar laws. Federal laws apply on federal lands.

21. **DO NOT** touch hot muffler, cylinder, or fins because contact may cause burns.

22. **DO NOT** run engine without air cleaner or air cleaner cover.

23. **DO NOT** operate during excessive vibration!

24. **DO NOT** leave machine unattended while in operation.

25. **DO NOT** park machine on a steep grade or slope.

WARNING: DO

1. **ALWAYS DO** remove the wire from the spark plug when servicing the engine or equipment TO PREVENT ACCIDENTAL STARTING.

2. **DO** keep cylinder fins and governor parts free of grass and other debris which can affect engine speed.

3. **DO** pull starter cord slowly until resistance is felt. Then pull cord rapidly to avoid kickback and prevent hand or arm injury.

4. **DO** examine muffler periodically to be sure it is functioning effectively. A worn or leaking muffler should be repaired or replaced as necessary.

5. **DO** use fresh gasoline. Stale fuel can gum carburetor and cause leakage.

6. **DO** check fuel lines and fittings frequently for cracks or leaks. Replace if necessary

7. **Follow** engine manufacturer operating and maintenance instructions.

8. **Inspect** machine and work area before starting unit.

6

TABLE OF CONTENTS

SAFETY INSTRUCTIONS	2
GENERAL SAFETY	3
ASSEMBLY	3
CONTROLS	4
LABELS	4 - 5
OPERATION	6 - 9
MAINTENANCE	10
PARTS DRAWING & LIST...	14 - 15
TROUBLESHOOTING	16
WARRANTY PROCEDURE	16

7

SOUND

Sound tests conducted were in accordance with 2000/14/EEC and were performed on 2/13/2002 under the conditions listed:

NOTE: Sound power level listed is the highest value for any model in this manual. Please refer to serial plate on the unit for the sound power level for your model.

Sound level of 82 dBA at operator position



101 dB

(PR550 MODEL)

GENERAL CONDITION:	Sunny
TEMPERATURE:	48° F (8.9° C)
WIND SPEED:	2 MPH (3.2 kmh)
WIND DIRECTION:	South East
HUMIDITY:	29 %
BAROMETRIC PRESSURE:	30.34" Hg (770mm Hg)

8

VIBRATION

VIBRATION LEVELS 3.2 g max.

Vibration levels at the operators handles were measured in the vertical, lateral, and longitudinal directions using calibrated vibration test equipment. Tests were performed on 09/08/97 under the conditions listed:

GENERAL CONDITION:	Sunny
TEMPERATURE:	85° F (29.4° C)
WIND SPEED:	10 MPH (16.1 kmh)
WIND DIRECTION:	East
HUMIDITY:	31 %
BAROMETRIC PRESSURE:	29.91" Hg (760mm Hg)

GENERAL SAFETY

For your safety and the safety of others, these directions should be followed:



Do not operate this machine without first reading owner's manual and engine manufacturer's manual.



Use of Ear Protection is recommended while operating this machine.



Use of Eye and Breathing protection is recommended when using this machine, especially in dry and dusty conditions.



Wearing gloves is recommended while operating this machine.

- **DO NOT** place hands or feet underneath unit, near debris outlet or near any moving parts.
- **DO NOT** start engine without height adjust lever in up position and clutch bail disengaged.
- **DO NOT** start or operate machine with guards removed.
- **DO NOT** perform any service on the unit without removing the spark plug wire.

- **DO NOT** operate a machine that exhibits excessive vibration.
- **DO NOT** operate this machine on slopes greater than 19°.
- **DO NOT** use this unit on any surface other than grass lawns.
- **DO NOT** allow children to operate this equipment.

- **DO** read all maintenance and operating instructions before beginning work.
- **DO** read all engine manufacturers operating and maintenance instructions.
- **DO** inspect lawn before beginning work. Remove all rocks, wire, string, or other objects that can present a hazard during work prior to starting.
- **DO** identify and mark all fixed objects to be avoided during work, such as sprinkler heads, water valves, buried cables, or clothes line anchors, etc.

ASSEMBLY



Read all safety and operating instructions before assembling or starting this unit.



PUT OIL IN ENGINE BEFORE STARTING

1. **UNFOLD** the upper handle (item 26) and slide handle lock loops (item 28) into place to secure the upper handle to the lower.
2. **CHECK** engine oil level and fill to proper level with engine manufacturers recommended grade of oil. Move height adjust lever to down position, to level engine during checking. See engine manufacturers instruction manual.
3. **CONNECT** spark plug wire.

Your Billy Goat Power Rake is shipped from the factory in one carton, completely assembled.

PACKING CHECKLIST

These items should be included in your carton. If any of these parts are missing, contact your dealer.

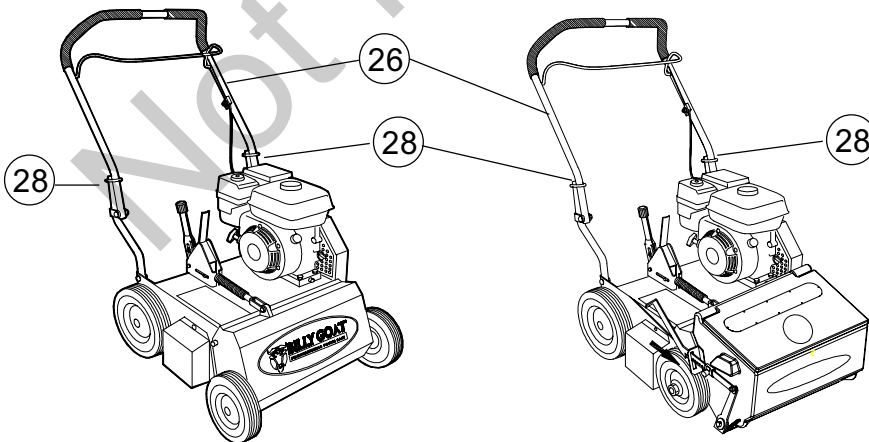

PR550, PR550H,
PR550V, & PR550HV

OS551 & OS551H

Engine Manual Per Model	Check <input type="checkbox"/>	<i>Per Model</i> Briggs & Stratton 5.5 Intek OHV
	Check <input type="checkbox"/>	Honda 5.5 OHV
Literature Assembly 350110	Check <input type="checkbox"/>	Owner's Manual 350324
	Check <input type="checkbox"/>	Literature PR Accessories 350140
	Check <input type="checkbox"/>	Warranty Card 400972
	Check <input type="checkbox"/>	EU Declaration of Conformity & EU Distributor List 350139

HONDA ENGINE THROTTLE CONTROL

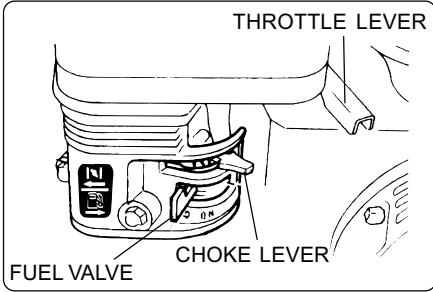

B & S ENGINE THROTTLE CONTROL

Set lever to choke position when starting a cold engine

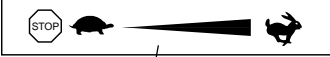

Set lever to desired engine speed.
Move lever completely to the left to stop engine

Briggs & Stratton



WARNING

- Read and follow Operating Instructions before running engine.
- Gasoline is flammable. Allow engine to cool at least 2 minutes before fueling.
- Engines emit carbon monoxide, DO NOT run in enclosed area.

Honda

IMPORTANT ENGINE INFORMATION: HONDA MOTOR CO., LTD
ENGINE FAMILY: THN163U1G1RA DISPLACEMENT - 163cm³
TUNE UP SPECIFICATION "REFER TO OWNER'S MANUAL FOR
MAINTENANCE SPECIFICATIONS AND ADJUSTMENTS". THIS ENGINE MEETS 1995 CALIFORNIA EMISSION REGULATIONS FOR UTILITY AND LAWN AND GARDEN EQUIPMENT ENGINES

- READ OWNER'S MANUALS BEFORE OPERATION.
- LIRE LE MANUEL D'UTILISATEUR AVANT USAGE.
- VOR INBETRIEBNAHME UNBEDINGT BEDIENUNGSANLEITUNG DURCHLESEN.
- NO UTILIZAR SIN ANTES NO HABER LEIDO EL MANUAL.

OIL ALERT

■ WHEN OIL LEVEL LOW, ENGINE STOPS IMMEDIATELY.

These labels should be included on your Power Rake. If any of these labels are damaged, replace them before putting this equipment into operation. Item and part numbers are given to help in ordering replacement labels.



Label Clutch Item 49
Part No. 830503

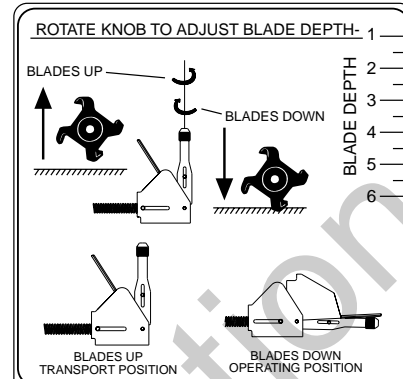

Label Do Not Fill While Engine Is Hot
Item 50 Part No. 400268



Label Danger Keep Hands and Feet Away
Item 51 Part No. 400424



Label Instructions Height Adjust
Item 35 Part No. 350176



Label Danger Guard
Item 52 Part No. 900327



Label Danger Flying Material
Item 48 Part No. 810736

LAWN PREPARATION:

- MOW LAWN TO LOWEST SETTING ON YOUR MOWER.
- DO NOT WATER PRIOR TO SEEDING.
- POWER RAKE TO DETHATCH LAWN AND REMOVE THATCH.
- FERTILIZE LAWN WITH BROADCAST SPREADER.

SEEDING RECOMMENDATIONS:

- FOR BEST RESULTS OVERSEED IN TWO PASSES OF ONE-HALF APPLICATION RATE AT RIGHT ANGLES OR IN A CRISS-CROSS PATTERN.
- WATER HEAVILY IMMEDIATELY THEN LIGHTLY FOR 10 - 14 DAYS KEEPING SOIL MOIST.
- AFTER GERMINATION, WATER LESS OFTEN TO PROMOTE GROWTH.

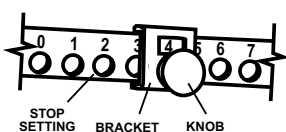

- PULL BACK ON THE KNOB THEN SLIDE THE BRACKET TO DESIRED STOP SETTING.

EXAMPLE: STOP SETTING IS ON 4

- IF SLICING WITHOUT DROPPING SEEDS FOR LONG PERIOD OF TIME THEN SET THE STOP SETTING TO ZERO.

SEED APPLICATION CHART:

THESE SETTINGS ARE APPROXIMATE GUIDELINES. SEEDING RATES ARE SPEED DEPENDENT. FASTER TRAVEL DELIVERS LESS SEED.

SEED TYPE	RATE LBS 1,000 FT ²	STOP SETTING	SEED TYPE	RATE LBS 1,000 FT ²	STOP SETTING
RYEGRASS	1/2	1	BENTGRASS	2/3	1
	3/4	2		1 1/3	2
	1 1/2	3	BERMUDAGRASS (HULLED & ZOYSIA)	3/4	1
	2 1/3	4		1 2/3	2
BLUEGRASS	3/4	3	CENTIPEDEGRASS (COATED)	2/3	1
	1	4		1 1/4	2
	1 1/2	5		2 1/2	3
	2 1/2	6	ST. AUGUSTINE GRASS	3/4	3
FESCUE	3/4	5		1	4
	1 1/4	6		1 1/3	5
	2	7	1 1/2	6	
	3 1/2	8			

REFERENCE CHART

BILLY GOAT SEEDER SETTING	SCOTTS SEEDER SETTING (ALL DROP SEEDER MODELS)
5	6 1/3
6	8
7	10
8	15 1/2
9	17

Label Instructions Seeder Box
Item 45 Part No. 350288

Operation

INTENDED USE: This machine is designed for removing thatch from your lawn, renovation of existing lawns, and to assist in overseeding operations. The machine should not be used for any other purpose than that stated above.

Do not operate if excessive vibration occurs. If excessive vibration occurs, shut engine off immediately and check for damaged or worn reel, loose pulley bolts or set screws, loose engine or lodged foreign objects. (See trouble shooting section on page 12).



Like all mechanical tools, reasonable care must be used when operating machine.

Inspect machine work area and machine before operating. Make sure that all operators of this equipment are trained in general machine use and safety.

STARTING ENGINE



ENGINE: See engine manufacturer's instructions for type and amount of oil and gasoline used.

Engine must be level when checking and filling oil and gasoline.

ENGINE SPEED: Controlled by throttle lever on the engine. Under normal conditions, operate at full throttle to accomplish your task.

FUEL VALVE: Move fuel valve to "ON" position (Honda only).

CHOKE: Operated with lever on the engine.

THROTTLE: Move throttle control on engine to fast position. Pull starting rope to start engine.

IF YOUR UNIT FAILS TO START:

See Troubleshooting on page 12.

FOLDING HANDLE

This unit is equipped with a folding upper handle for easier storage and transportation. The handle can be folded by sliding the handle lock loops (item 28) up. This releases the upper handle, allowing it to be folded over the unit.

HANDLING & TRANSPORTING



This unit requires two people to lift it. With the handle in the folded position, lift holding the lower handle and belt/shaft guard one on each side of the machine. Secure the machine in place during transport.

ADJUSTING BLADE DEPTH

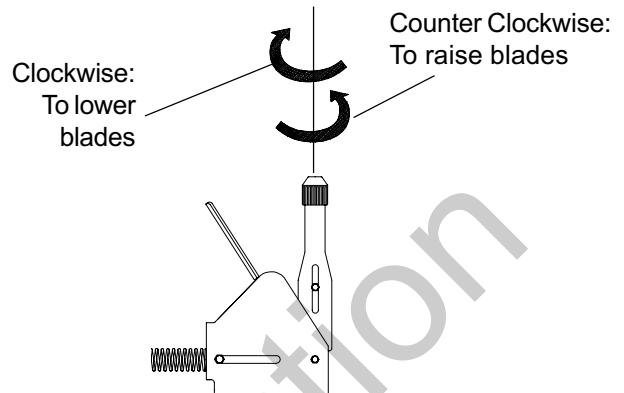

The depth of the blades can be raised or lowered by rotating the knob on the top of the adjustment lever. The blades are lowered by rotating the knob clockwise, and raised by rotating the knob counter-clockwise. The relative depth of the blades can be gauged by using the depth scale located on the right front corner of the engine base. With new blades installed the depth can be estimated as follows: 2.5 on the scale is even with the ground, 3 is equal to 0.25" deep, and 3.5 is equal to 0.5" deep

BLADE POSITION & DEPTH CONTROL LEVER

The blades can be raised or lowered into the ground by height adjustment lever on the engine base. The height adjuster lock lever must be pushed back against the adjustment lever in order to lower the blades into the ground. The resulting blade depth can be adjusted higher or lower.

See ADJUSTING BLADE DEPTH.

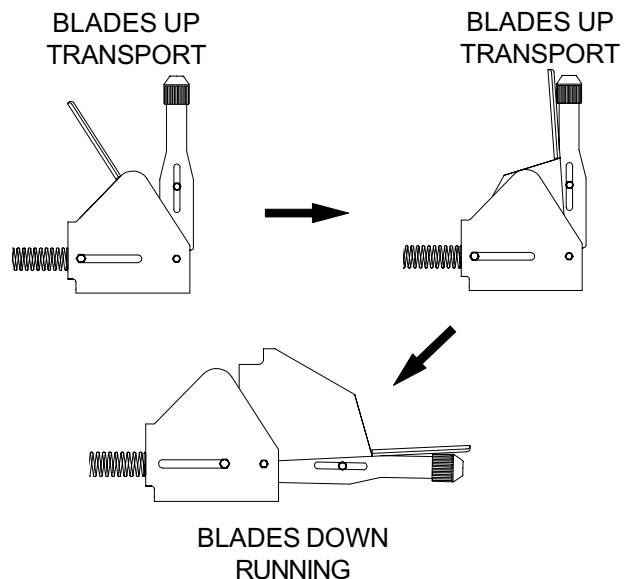

Hints!**RAKING/SLICING TIPS**

Before beginning, it is best to evaluate the condition of the lawn by cutting one or more core samples from area to be treated. A core can be cut using a piece of pvc, or metal pipe. Hammer the pipe into the ground, remove it, push the core out of the pipe and inspect it to determine the depth of thatch in your yard.

THATCH: Thatch is a dense layer of dead grass, clippings, and roots that builds up over time at the base of the lawn preventing air, water, and fertilizer from reaching the soil. This can cause shallow root development and make a lawn more susceptible to drought and disease. Thatch also provides an ideal environment for insects to hide and multiply. Periodic removal of thatch will keep your lawn in good health.

HEAVY THATCH: Lawns with an excessive amount of thatch will require multiple treatments for effective removal. Trying to remove excessive thatch (greater than 3/4"[19 mm] deep) in one treatment will damage or destroy the living part of the lawn. It is best to remove heavy thatch in seasonal treatments (i.e. spring, and fall).

SLOPES: Rake slopes across not up and down. This is much easier and safer for the operator and is better for the lawn. Raking across will help to reduce runoff during watering and allow the sloped ground to hold more seed, fertilizer, and water. The units maximum operating slope is 35% or 19°.

DEPTH: The wide range of depth adjustment on your unit is provided to allow for blade wear. Setting the reel deeper will not produce better, or quicker results. The flail reel is intended to be set so it just touches the surface on flat ground. The slicing reel should be set even with the ground for verti-slicing work, and set to a maximum 1/2" depth for overseeding jobs. Setting the reel deeper than this will only result in premature wear on the unit (i.e. failed belt). If you desire to work the ground deeper than the above guidelines allow, it should be done gradually in multiple passes..

SLICING / OVERSEEDING: Mow the lawn to shorter than the normal cut height before starting (i.e. approximately 2" tall for fescue grass). For the best result, Slice/Overseed in criss cross pattern (See Fig. 1 and See Fig 2).

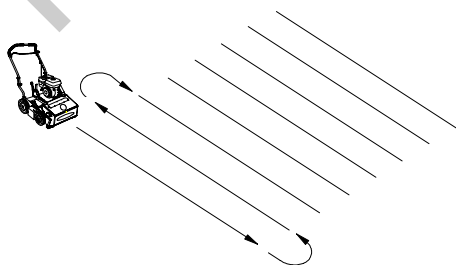

Fig. 1

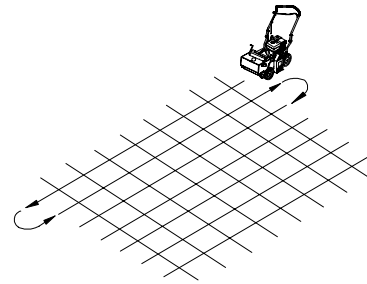

Fig. 2

RAKING OPERATION

DO NOT- Use this machine on any surface other than a lawn.

DO NOT- Use this machine on slopes in excess of 19°.

DO NOT- Allow persons unfamiliar with this equipment to operate it.

DO NOT- Allow children to operate this equipment.

NOTE: Must have the flail reel assembly (350112) for this operation.

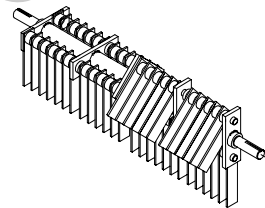

MOW: Mow the lawn to it's normal cut height.

DRY: Be sure grass is dry. Wet conditions can cause increased damage to healthy grass.

SET DEPTH: With engine off, set the raking depth so that the blades just touch on a flat surface (i.e. driveway, or sidewalk).

START ENGINE: See page 5 for further instruction.

ENGAGE BLADES: Pull back on the bail on the operators handle. **NOTE:** When engaging the blades in heavy load conditions (i.e. heavy thatch, or very uneven turf), push down on the operators handle lifting the front wheels slightly. Engage the blades. Slowly lower the unit into the turf.

RAKE: Rake a small test area and examine the results. Thatch should be removed and deposited on top of the healthy grass. If excessive damage occurs to healthy grass, adjust the blade depth to decrease damage. Continue raking the yard, working in one direction (i.e. north-south, or east-west). **NOTE:** If a large drop in engine RPM occurs, or the unit pulls you forward and bounces during operation the blade depth is set too low.

REMOVE THATCH: After raking, a layer of thatch will be deposited over the top of the lawn. This thatch must be removed prior to any fertilizing, seeding, or watering of the lawn. We suggest the use of a lawn vacuum or wheeled blower for collection and removal of the thatch.

VERTI-CUTTING OPERATION



- DO NOT-** Use this machine on any surface other than a lawn.
- DO NOT-** Use this machine on slopes in excess of 19°.
- DO NOT-** Allow persons unfamiliar with this equipment to operate it.
- DO NOT-** Allow children to operate this equipment.

NOTE: Must have the slicing reel assembly (350113) for this operation.

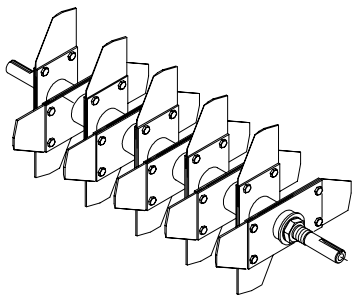

MOW: Mow the lawn to shorter than the normal cut height (approximately 2" tall)

DRY: Be sure grass is dry. Wet conditions can cause increased damage to healthy grass.

SET DEPTH: With engine off, set the raking depth so that the blades just touch on a flat surface (i.e. driveway, or sidewalk).

START ENGINE: See Page 5.

ENGAGE BLADES: Pull back on the bail on the operators handle. **NOTE:** When engaging the blades in heavy load conditions (i.e. heavy thatch, or very uneven turf), push down on the operators handle lifting the front wheels slightly. Engage the blades. Slowly lower the unit into the turf.

SLICE: Verti-cut a small test area and examine the results. Some thatch and cut stems should be removed and deposited on top of the healthy grass. Grass runners should be cut and ready for removal. If excessive damage occurs to healthy grass, adjust the blade depth to decrease damage. Continue raking the yard, working in one direction (i.e. north-south, or east-west). **NOTE:** If a large drop in engine RPM occurs, or the unit pulls you forward and bounces during operation the blade depth is set too low.

REMOVE THATCH/STEMS: After verti-cutting, a layer of thatch and cut stems will be deposited over the top of the lawn. We suggest the use of a lawn vacuum or wheeled blower for collection and removal of the thatch/stems.

OVERSEEDING OPERATION



- DO NOT-** Use this machine on any surface other than a lawn.
- DO NOT-** Use this machine on slopes in excess of 19°.
- DO NOT-** Allow persons unfamiliar with this equipment to operate it.
- DO NOT-** Allow children to operate this equipment.

NOTE: Must have the slicing reel assembly (350113) for this operation.

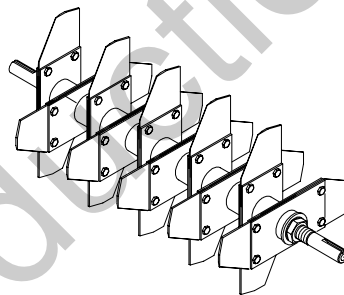

MOW: Mow the lawn to shorter than the normal cut height (approximately 2" tall)

DRY: Be sure grass is dry. Wet conditions can cause increased damage to healthy grass.

SEED: Spread grass seed according to the seed suppliers directions (e.g. 10 lbs. per 1000 ft² [4.5 kg. per 93 m²])

SET DEPTH: With engine off, set the raking depth so that the blades reach 1/4"-1/2" (6-12 mm) below a flat surface (i.e. driveway, or sidewalk).

START ENGINE: See Page 5.

ENGAGE CLUTCH: Pull back on the bail on the operators handle. **NOTE:** When engaging the clutch in heavy load conditions (i.e. heavy thatch, or very uneven turf), push down on the operators handle lifting the front wheels slightly. Engage the clutch. Slowly lower the unit into the turf.

SLICE: Run machine over the area that has been seeded to incorporate the seed into the soil. If excessive damage occurs to healthy grass, adjust the blade depth to decrease damage. Continue raking the yard, working in one direction (i.e. north-south, or east-west). **NOTE:** If a large drop in engine RPM occurs, or the unit pulls you forward and bounces during operation the blade depth is set too low.

WATER/FERTILIZE: After the seed has been worked into the soil, water and fertilize according to the seed suppliers directions.

ADJUSTING SEED RATE

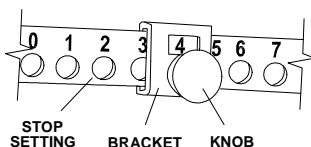

- PULL BACK ON THE KNOB THEN SLIDE THE BRACKET TO DESIRED STOP SETTING.
EXAMPLE: STOP SETTING IS ON 4
 - IF SLICING WITHOUT DROPPING SEEDS FOR LONG PERIOD THEN SET THE STOP SETTING TO ZERO .

DROPPING SEEDS

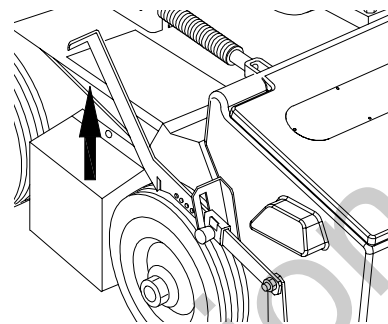

- AFTER ADJUSTING THE STOP SETTING, LIFT UP ON THE BAR TO OPEN THE DROP SEEDER DOOR.

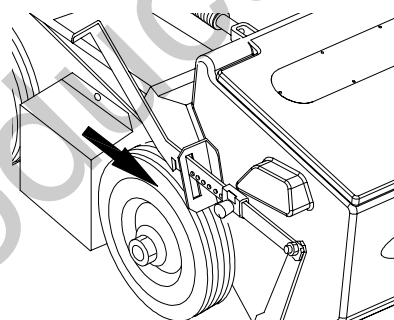

- TO STOP DROPPING SEEDS, PUSH FORWARD ON THE HANDLE TO CLOSE THE DROP SEEDER DOOR.
NOTE: IF SLICING WITHOUT DROPPING SEEDS FOR LONG PERIOD OF TIME THEN SET THE STOP SETTING TO ZERO .

LAWN PREPARATION

- MOW LAWN TO LOWEST SETTING ON YOUR MOWER.
- DO NOT WATER PRIOR TO SEEDING.
- POWER RAKE TO DETHATCH LAWN AND REMOVE THATCH.
- FERTILIZE LAWN WITH BROADCAST SPREADER.

LAWN PREPARATION

- FOR BEST RESULTS OVERSEED IN TWO PASSES OF ONE-HALF APPLICATION RATE AT RIGHT ANGLES OR IN A CRISS-CROSS PATTERN.
- WATER HEAVILY IMMEDIATELY THEN LIGHTLY FOR 10-14 DAYS KEEPING SOIL MOIST.
- AFTER GERMINATION, WATER LESS OFTEN TO PROMOTE GROWTH.

SEED APPLICATION CHART:

THESE SETTINGS ARE APPROXIMATE GUIDELINES. SEEDING RATES ARE SPEED DEPENDENT. FASTER TRAVEL DELIVERS LESS SEED.

SEED TYPE	RATE LBS 1,000 FT ²	STOP SETTING	SEED TYPE	RATE LBS 1,000 FT ²	STOP SETTING
RYEGRASS	1/2	1	BENTGRASS	2/3	1
	3/4	2		1 1/3	2
	1 1/2	3	BERMUDAGRASS (HULLED & ZOYSIA)	3/4	1
	2 1/3	4		1 2/3	2
BLUEGRASS	3/4	3	CENTIPEDEGRASS (COATED)	2/3	1
	1	4		1 1/4	2
	1 1/2	5		2 1/2	3
	2 1/2	6	ST. AUGUSTINE GRASS	3/4	3
FESCUE	3/4	5		1	4
	1 1/4	6		1 1/3	5
	2	7		1 1/2	6
3 1/2	8				

REFERENCE CHART

BILLY GOAT SEEDER SETTING	SCOTTS SEEDER SETTING (ALL DROP SEEDER MODELS)
5	6 1/3
6	8
7	10
8	15 1/2
9	17

MAINTENANCE



Use only a qualified mechanic for any adjustments, disassembly or any kind of repair .



WARNING: TO AVOID PERSONAL INJURY, ALWAYS TURN MACHINE OFF, MAKE SURE ALL MOVING PARTS COME TO A COMPLETE STOP.



DISCONNECT SPARK PLUG WIRE BEFORE SERVICING UNIT.



ENGINE: See engine manufacturer operator's instructions.



RECONNECT SPARK PLUG WIRE, AND ALL GUARDS, BEFORE STARTING ENGINE.



USE ONLY BILLY GOAT ORIGINAL EQUIPMENT PARTS FOR REPLACEMENT AND REPAIR

BLADE WEAR AND ROTATING REEL END TO END

FLAIL BLADE WEAR

1. Wait for engine to cool and disconnect spark plug.
2. Close fuel valve on engine (if available).
3. Lean unit back onto lower handles and secure in place.
4. Inspect blades for wear, and immediately replace any bent or cracked blades. Measure the overall length of the blade. (See fig. 1)
5. If blades measure less than 3.25"(83 mm) in overall length they must be replaced. NOTE: We recommend replacing all the flails at once.

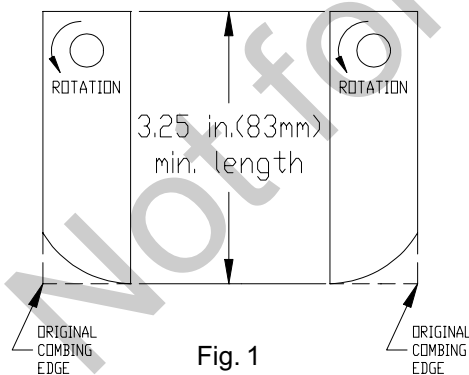

Fig. 1

SLICING BLADE WEAR

1. Wait for engine to cool and disconnect spark plug.
2. Close fuel valve on engine (if available).
3. Lean unit back onto lower handles and secure in place.
4. Inspect blades for wear, and immediately replace any bent or cracked blades. Measure the overall length of the blade from the center of the attachment bolt to the tip of the worn blade.
5. If blades measure less than 3"(76 mm) in length they must be replaced. NOTE: We recommend replacing all the blades at once.

ROTATING FLAIL REEL END TO END

To maximize flail blade life and performance the reel can be rotated end to end periodically to provide a fresh lead cutting edge. Takes approx. 20 min. and requires 1/2" and 9/16" socket wrenches with extension bar.

1. Wait for engine to cool and disconnect spark plug.
2. Close fuel valve on engine (if available).
3. Lean unit back onto lower handles and secure in place.
4. Remove (6) lock nuts(item 62) holding the belt and shaft guards(item 21 &22) in place. It is necessary to lower the height adjust lever to reach the locknuts on the guards. Remove the guards.
5. Remove the drive belt(item 9) by "walking" it out of the groove on the reel pulley(item 2).
6. Remove the (4) lock nuts(item 60) and washers(item 68) holding the bearings(item 23) to the frame of the unit.
7. The reel is now free from the machine. Slide the reel down and out of the machine.
8. Remove the capscrew(item 71), lockwasher(item 57), reel pulley(item 2), key(item 42), and reel spacer(item 10) from the end of the reel.
9. Rotate the reel end to end, and re-install these items on the opposite end of the reel.
10. Re-install the reel in reverse order of removal. Re-install the guards in reverse order of removal.

DRIVE BELT REPLACEMENT

NOTE: Takes approx. 10 min. and requires 1/2" socket wrench with extension.

1. Wait for engine to cool and disconnect spark plug.
2. Remove (3) lock nuts(item 62) holding the belt guard(item 21) in place. It is necessary to lower the height adjust lever to reach the locknuts on the guard. Remove the guard.
3. Remove the belt(item 9) by rotating the reel pulley(item 2) and walking it out of the groove. Discard old belt
4. Install new belt using same procedure to walk the belt into the groove.
5. With new belt installed pull bail rod back to engaged position and measure extension of idler spring. Spring should stretch 3/4" - 1" (19 25 mm) with bail engaged. Adjust clutch cable as necessary to achieve this extension.
6. Re-install the belt guard.

Maintenance Schedule

Follow these hourly maintenance intervals.

Maintenance Operation	Every Use (Daily)	Every 25 hrs
Engine (See Engine Manual)		
Check engine oil	●	
Inspect and clean engine air filter	●	
Grease reel bearings		●
Inspect belt		●
Inspect for loose, worn, or damaged parts		●
Oil height adjustment linkage		●

POWER RAKE SEEDER BOX KIT

P/N 350325

PARTS DRAWING

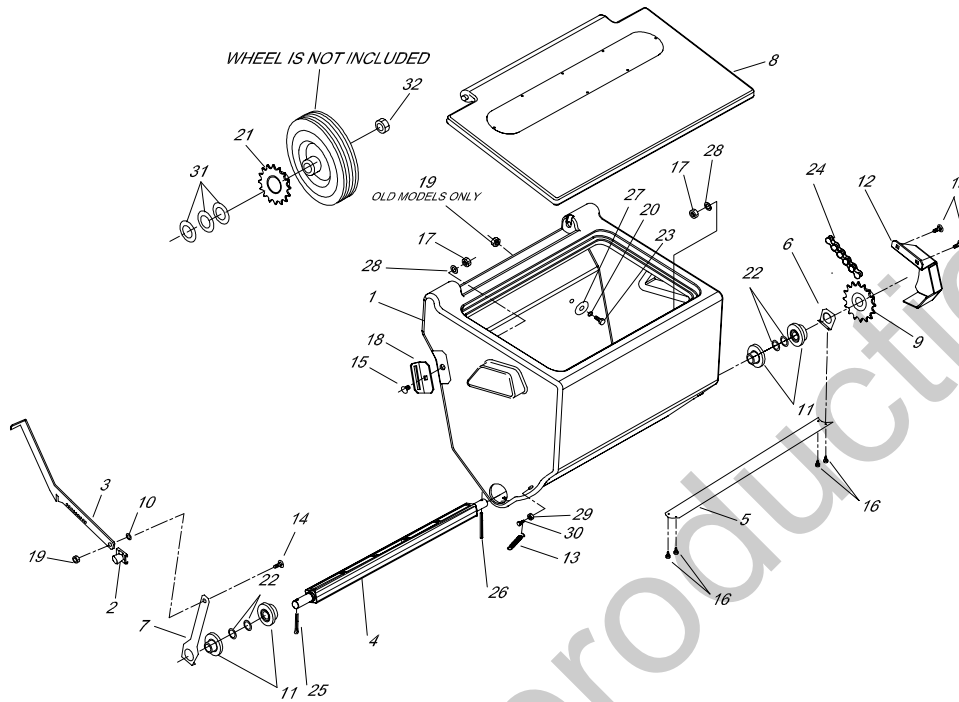

PARTS LIST			
ITEM NO.	PART NO.	DESCRIPTION	QTY
1	350321	BOX PLASTIC DROP SEEDER MAIN BODY	1
2	350306	BRACKET ADJ DROP SEEDER ASSY	1
3	350276	BAR DOOR LINKGAGE	1
4	350320	SHAFT PLASTIC DROOP SEEDER	1
5	350271	PLATE DOOR DROP SEEDER	1
6	350272	PLATE DOOR DROP SEEDER END	1
7	350273	PLATE DOOR DROP SEEDER ARM	1
8	350322	BOX PLASTIC DROP SEEDER LID ASSEMBLY	1
9	350319	SPROCKET 16T #43 0.625 BORE	1
10	8171003	WASHER 5/16 FLAT CUT	1
11	900321	BEARING CLIP 1.375 OD	4
12	350335	GUARD SPROCKET	1
13	400217	SPRING TENSION	2
14	8024040	BOLT CARRAIGE 5/16 - 18 X 1	1
15	8024021	BOLT CARRIAGE 1/4-20 X 3/4"	1
16	350286	SCREW SHEET METAL	4
17	8160001	NUT LOCK 1/4	1
18	350332	BRACKET SLOT PLASTIC SEEDER BOX	1
19	8160002	NUT LOCK 5/16	1
21	350318	SPROCKET WHEEL 16T	1
22	350280	WASHER 0.906 OD X 0.656 ID	4
24	350329	CHAIN 35 PITCH	1
25	8197031	PIN COTTER 1/8" X 1"	1
26	350331	ROLL PIN 1/8 - 1 3/4	1
28	8172007	WASHER 1/4 SAE	1
29	8154007	NUT HEX 10-24	2
30	8059136	SCREWCAP #10-24 X 3/4	2
PARTS BAG SEEDER BOX KIT			
15	8024021	BOLT CARRIAGE 1/4-20 X 3/4"	2
17	8160001	NUT LOCK 1/4	2
19	8160002	NUT LOCK 5/16 (REQUIRE ON THE OLD MODELS ONLY)	4
20	8177011	WASHER LOCK 5/16	4
23	8041026	SCREWCAP 5/16-18 x 3/4	4
27	8172020	WASHER 5/16 FENDER	4
28	8172007	WASHER 1/4 SAE	2
31	8171006	WASHER 1/2 FC	3
32	8161044	NUT LOCK 1/2" THIN HGT	1
-	350327	LIT SEEDER BOX (INCLUDES TEMPLATE)	1

FLAIL REEL ASSY 350112

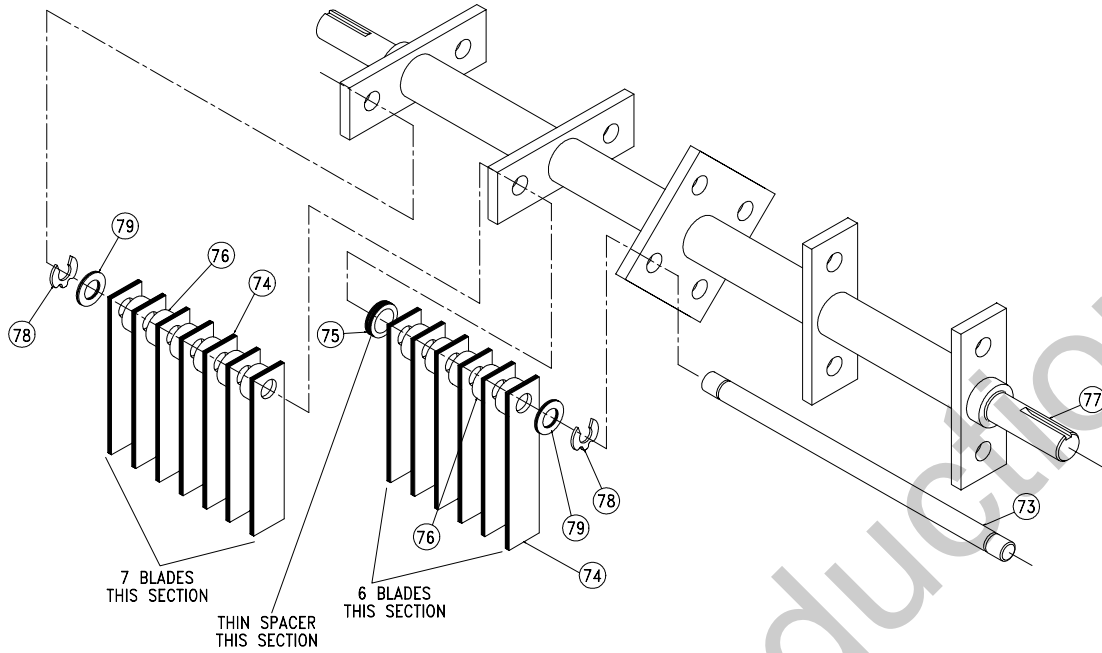

item no.	PARTS LIST	PR500 Part No.	QTY
73	SHAFT FLAIL BLADE	350141	4
74	BLADE FLAIL	350100	52
75	SPACER BUMPER 5/8" x 1/4"	350143	4
76	SPACER BUMPER 5/8" x 1/2"	350144	44
77	SHAFT WA FLAIL REEL	350145	1
78	CLIP LOCK 1/2"	350146	8
79	WASHER 1/2 SAE	8172011	8

FLAIL SHAFT KIT 350185

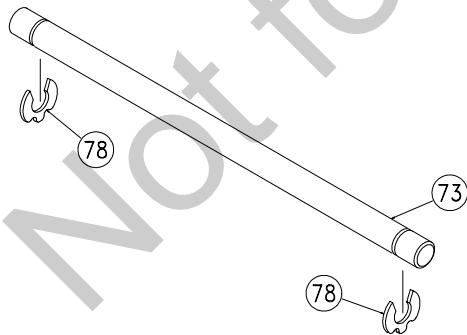

item no.	PARTS LIST	Part No.	QTY
73	SHAFT FLAIL BLADE	350141	4
78	CLIP LOCK 1/2"	350146	8

FLAIL BLADE KIT 350186

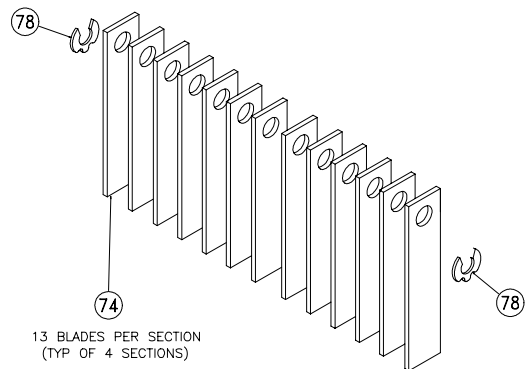

item no.	PARTS LIST	Part No.	QTY
74	BLADE FLAIL	350100	52
78	CLIP LOCK 1/2"	350146	8

SPACER BUMPER KIT 350258

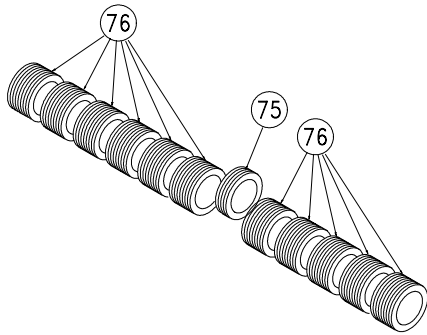

item no.	PARTS LIST	PR500 Part No.	QTY
75	SPACER BUMPER 5/8" x 1/4"	350143	4
76	SPACER BUMPER 5/8" x 1/2"	350144	44

SLICING BLADE KIT 350187

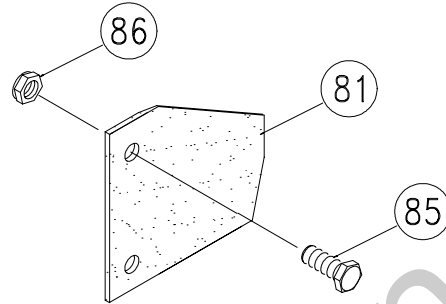

item no.	PARTS LIST	PR500 Part No.	QTY
81	BLADE SLICING REEL	350147	20
85	SCREWCAP 1/4-20 x 3/4, GR. 5	350151	40
86	NUT LOCK 1/4-20	8142004	40

SLICING REEL ASSY 350113

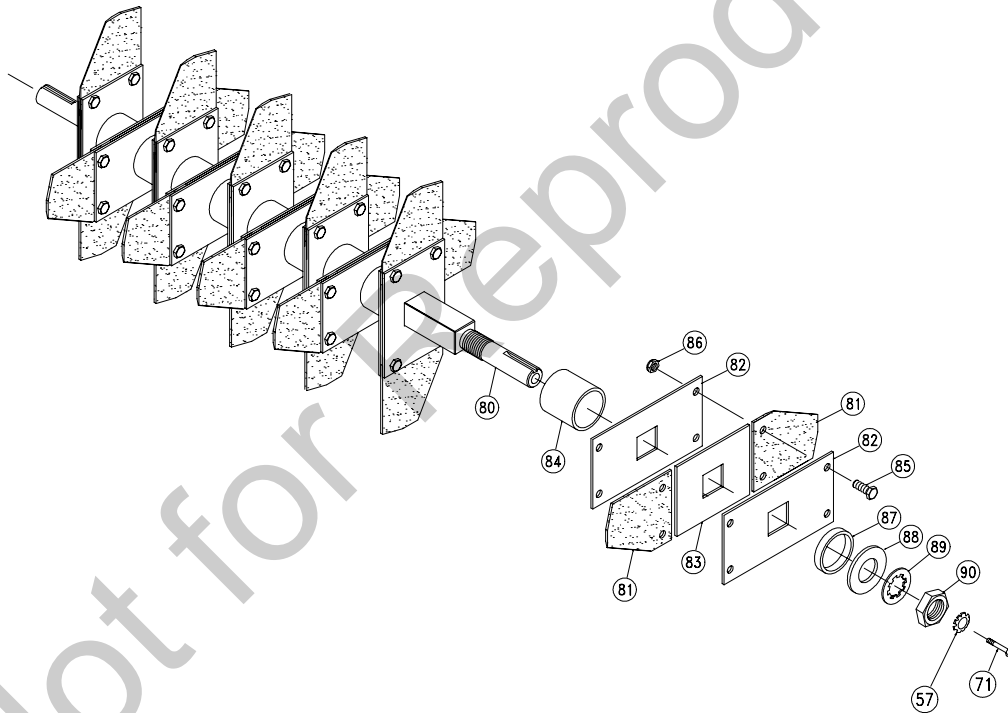

item no.	PARTS LIST	PR500 Part No.	QTY
57	LOCK WASHER 5/16 TWISTED TOOTH	800177	1
71	SCREWCAP 5/16 - 24 x 1" HCS GR. 5	400164	1
80	SHAFT SLICING WA	350142	1
81	BLADE SLICING REEL	350147	20
82	PLATE BLADE MTG.	350148	20
83	SPACER BLADE MTG.	350149	10
84	SPACER BLADE ASSY	350150	9
85	SCREWCAP 1/4-20 x 3/4, GR. 5	350151	40
86	NUT LOCK 1/4-20	8142004	40
87	COLLAR SPACER	350152	1
88	WASHER 0.937 x 1.750 x 0.119	350153	1
89	WASHER LOCK 7/8 INT. TOOTH	350154	1
90	NUT JAM 7/8-14	350155	1



BILLY GOAT

18 PARTS DRAWING

PR550, PR550V, PR550H
PR550HV, OS551, OS551H

SEEDER BOX ASSEMBLY IS
FOR THE OS MODELS ONLY

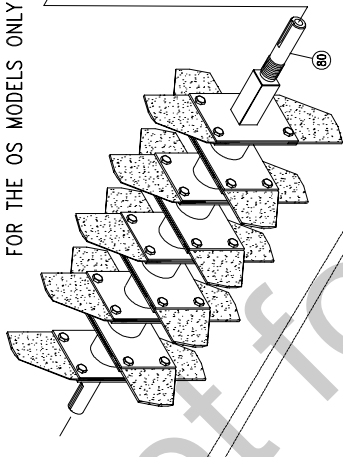

FOR THE OS MODELS ONLY

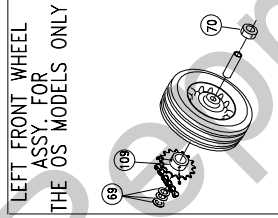

LEFT FRONT WHEEL
ASSY. FOR
THE OS MODELS ONLY

SEEDER BOX ASSEMBLY IS
FOR THE OS MODELS ONLY

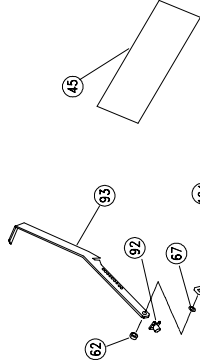

SEEDER BOX ASSEMBLY IS
FOR THE OS MODELS ONLY

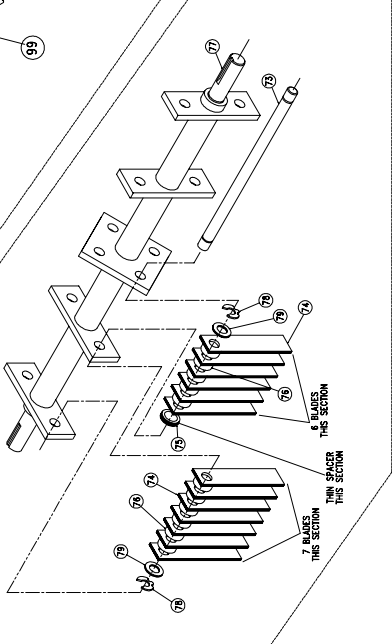

7 BLADES
THIS SECTION
THIN SPACER
THIS SECTION
4 BLADES
THIS SECTION

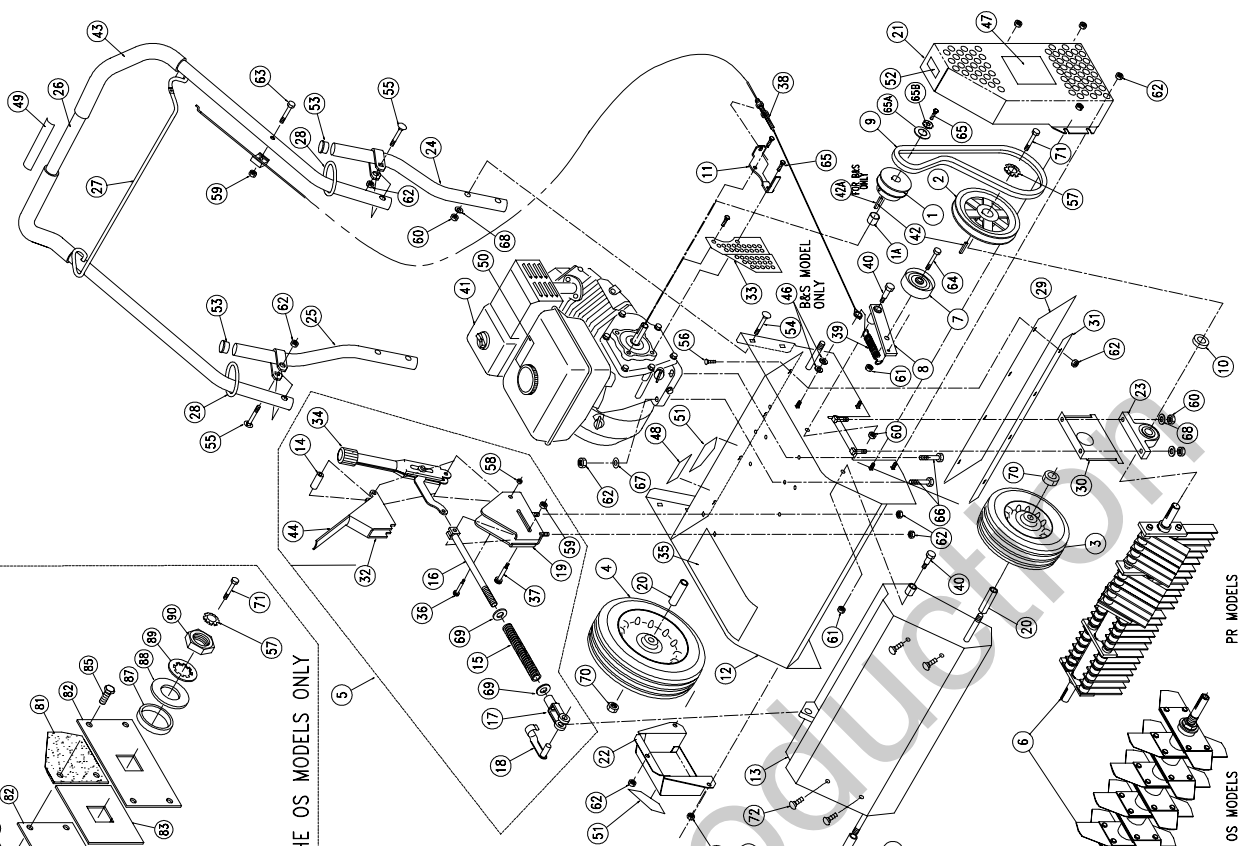

OS MODELS
PR MODELS

SEE PAGE 10 FOR PARTS LIST
FOR SLICING AND FLAIL REEL

item no.	PARTS LIST	PR550	QTY	PR550H	QTY	OS551	QTY	OS551H	QTY
		Part No.		Part No.		Part No.		Part No.	
1	Pulley 3" OD	350101-01	1	350101	1	350101-01	1	350101	1
1A	Spacer Crank PR Honda	-	-	350339	1	-	-	350339	1
2	Pulley 6.5" OD X 3/4"	350102	1	350102	1	350102	1	350102	1
3	Wheel 8" Front PR	350103	2	350103	2	350103	2	350103	2
4	Wheel 10" Front PR	350104	2	350104	2	350104	2	350104	2
5	Height Adjust Assy	350107	1	350107	1	350107	1	350107	1
6	Reel Flail / Slicing Assy	350112	1	350112	1	350113	1	350113	1
7	Pulley Idler 2.75"	350114	1	350114	1	350114	1	350114	1
8	Arm Idler WA	350115	1	350115	1	350115	1	350115	1
9	Belt 5L X 36	350116	1	350116	1	350116	1	350116	1
10	Spacer Reel Pulley	350118	1	350118	1	350118	1	350118	1
11	Bracket Mount Clutch Cable	350119	1	350119	1	350119	1	350119	1
12	Chassis WA W/ Label	350194	1	350194	1	350194	1	350194	1
13	Frame Front WA	350121	1	350121	1	350121	1	350121	1
14	Bushing 0.375 OD X 0.256 ID X 0.88	350309	1	350309	1	350309	1	350309	1
15	Spring Height Adjust PR500	350125	1	350125	1	350125	1	350125	1
16	Link Height Adjust PR500	350126	1	350126	1	350126	1	350126	1
17	Yoke 1/2 - 20	350127	1	350127	1	350127	1	350127	1
18	Pin Yoke 1/2"	350128	1	350128	1	350128	1	350128	1
19	Bracket Mount Hgt. Adj. WA	350182	1	350182	1	350182	1	350182	1
20	Spacer Spanner Wheel PR500	350130	4	350130	4	350130	4	350130	4
21	Guard Belt WA W/ Label	350195	1	350195	1	350195	1	350195	1
22	Guard Shaft WA W/ Label	350196	1	350196	1	350196	1	350196	1
23	Bearing 3/4" Cast Pillow Block	350133	2	350133	2	350133	2	350133	2
24	Handle Lower LH WA	350134	1	350134	1	350134	1	350134	1
25	Handle Lower RH WA	350135	1	350135	1	350135	1	350135	1
26	Handle Upper PR500	350136	1	350136	1	350136	1	350136	1
27	Bail Clutch WA	350137	1	350137	1	350137	1	350137	1
28	Loop Folding Handle	350138	2	350138	2	350138	2	350138	2
29	Deflector Rubber	350167	1	350167	1	350167	1	350167	1
30	Shield Bearing	350168	2	350168	2	350168	2	350168	2
31	Bar Clamp Deflector	350171	1	350171	1	350171	1	350171	1
32	Bracket Height Adjust Lock WA	350173	1	350173	1	350173	1	350173	1
33	Guard Pulley Back	350184	1	350174	1	350184	1	350174	1
34	Lever Height Control	350175	1	350175	1	350175	1	350175	1
35	Label Instr. Hgt. Adj.	350176	1	350176	1	350176	1	350176	1
36	Bolt Shoulder 1/2" x 1 3/4"	350178	1	350178	1	350178	1	350178	1
37	Bolt Shoulder 5/16" x 1 3/4"	350179	1	350179	1	350179	1	350179	1
38	Cable Clutch Reel PR500	350181	1	350181	1	350181	1	350181	1
39	Spring Extension	400217	1	400217	1	400217	1	400217	1
40	Bolt Shoulder 1/2" X 1"	500114	3	500114	3	500114	3	500114	3
41	ENGINE HONDA 5.5 H.P. GX160	-	-	600115	1	-	-	600115	1
	ENGINE INTEK 5.5HP OHV B&S	350197	1	-	-	350197	1	-	-
42	KEY 3/16" X 1"	9201078	1	9201078	2	9201078	1	9201078	2
42A	KEY 1/4" x 1"	9201113	1	-	-	9201113	1	-	-
43	GRIP 1" x 13"	400570	2	400570	2	400570	2	400570	2
44	GRIP LEVER 1/8 x 1 x 5"	500181	1	500181	1	500181	1	500181	1
45	LABEL INSTRUCTION SEEDER BOX	-	-	-	-	350288	1	350288	1
46	WASHER 5/16 FC (BELT GUARD)	8171003	2	-	-	8171003	2	-	-
47	LABEL GOAT HEAD	850209	1	850209	1	850209	1	850209	1
48	LABEL DANGER THROWN OBJECT	810736	1	810736	1	810736	1	810736	1
49	LABEL CLUTCH VQ	830503	1	830503	1	830503	1	830503	1
50	LABEL HOT ENGINE	400268	1	400268	1	400268	1	400268	1
51	LABEL WARNING	400424	2	400424	2	400424	2	400424	2
52	LABEL DANGER GUARD	900327	1	900327	1	900327	1	900327	1
53	PLUG CAP 1" RD	890132	2	890132	2	890132	2	890132	2
54	BOLT CARRAIGE 3/8-16 x 1 3/4	8024061	4	8024061	4	8024061	4	8024061	4
55	BOLT CARRAIGE 5/16-18 x 1 3/4	8024043	2	8024043	2	8024043	2	8024043	2
56	BOLT CARRIAGE 5/16 -18 x 3/4	8024039	4	8024039	4	8024039	5	8024039	5
57	LOCK WASHER TW. TOOTH	400502	1	400502	1	800177	1	800177	1
58	NUT LOCK #10-24	8164005	1	8164005	1	8164005	1	8164005	1
59	NUT LOCK 1/4-20	8160001	2	8160001	2	8160001	5	8160001	5
60	NUT LOCK 3/8-16	8160003	9	8160003	9	8160003	9	8160003	9

item no.	PARTS LIST	PR550	QTY	PR550H	QTY	OS551	QTY	OS551H	QTY
		Part No.		Part No.		Part No.		Part No.	
61	NUT LOCK 3/8-16 THIN	8161042	3	8161042	3	8161042	3	8161042	3
62	NUT LOCK 5/16-18	8160002	18	8160002	18	8160002	19	8160002	19
63	SCREWCAP 1/4-20 x 1 1/2	8041008	1	8041008	1	8041008	1	8041008	1
64	SCREWCAP 3/8 - 16 x 1 1/4	8041051	1	8041051	1	8041051	1	8041051	1
65	SCREWCAP 5/16-24 x 3/4" GR.5	8042026	3	8042026	4	8042026	3	8042026	4
65A	Washer 3/4 SAE	-	-	8172015	1	-	-	8172015	1
65B	Washer 5/16 Twist Tooth	-	-	430298	1	-	-	430298	1
66	SCREWCAP 5/16 - 18 x 1 1/2	8041030	4	8041030	4	8041030	4	8041030	4
67	WASHER 5/16 FLAT CUT	8171003	4	8171003	4	8171003	8	8171003	8
68	WASHER 3/8 FLAT CUT	8171004	8	8171004	8	8171004	8	8171004	8
69	WASHER 1/2 FC	8171006	2	8171006	2	8171006	5	8171006	5
70	NUT LOCK 1/2" - 13 THIN HGT	8161044	4	8161044	4	8161044	4	8161044	4
71	SCREWCAP REEL PULLEY	8041050	1	8041050	1	400164	1	400164	1
72	BUTTON SOCKET 5/16-18X5/8"	350266	4	350266	4	-	-	-	-

FLAIL REEL ASSEMBLY (FOR PR550 AND PR550H MODELS ONLY)

73	SHAFT FLAIL BLADE	350141	4	350141	4	-	-	-	-
74	BLADE FLAIL	350100	52	350100	52	-	-	-	-
75	SPACER BUMPER 5/8" x 1/4"	350143	4	350143	4	-	-	-	-
76	SPACER BUMPER 5/8" x 1/2"	350144	44	350144	44	-	-	-	-
77	SHAFT WA FLAIL REEL	350145	1	350145	1	-	-	-	-
78	CLIP LOCK 1/2"	350146	8	350146	8	-	-	-	-
79	WASHER 1/2 SAE	8172011	8	8172011	8	-	-	-	-

SLICING REEL ASSEMBLY (FOR PR550V, PR550HV, OS551, AND OS551H MODELS ONLY)

80	SHAFT SLICING WA	350142	1	350142	1	350142	1	350142	1
81	BLADE SLICING REEL	350147	20	350147	20	350147	20	350147	20
82	PLATE BLADE MTG.	350148	20	350148	20	350148	20	350148	20
83	SPACER BLADE MTG.	350149	10	350149	10	350149	10	350149	10
84	SPACER BLADE ASSY	350150	9	350150	9	350150	9	350150	9
85	SCREWCAP 1/4-20 x 3/4, GR. 5	350151	40	350151	40	350151	40	350151	40
86	NUT LOCK 1/4-20	8142004	40	8142004	40	8142004	40	8142004	40
87	COLLAR SPACER	350152	1	350152	1	350152	1	350152	1
88	WASHER 0.937 x 1.750 x 0.119	350153	1	350153	1	350153	1	350153	1
89	WASHER LOCK 7/8 INT. TOOTH	350154	1	350154	1	350154	1	350154	1
90	NUT JAM 7/8-14	350155	1	350155	1	350155	1	350155	1

SEEDER BOX ASSEMBLY (FOR OS551, AND OS551H MODELS ONLY)

91	BOX SEEDER MAIN BODY	-	-	-	-	350321	1	350321	1
92	BRACKET ADJ DROP SEEDER	-	-	-	-	350306	1	350306	1
93	BAR DOOR LINKGAGE	-	-	-	-	350276	1	350276	1
94	SHAFT PLASTIC DROOP SEEDER	-	-	-	-	350320	1	350320	1
95	PLATE DOOR DROP SEEDER	-	-	-	-	350271	1	350271	1
96	PLATE DOOR DROP SEEDER END	-	-	-	-	350272	1	350272	1
97	PLATE DOOR DROP SEEDER ARM	-	-	-	-	350273	1	350273	1
98	BOX SEEDER LID ASSEMBLY	-	-	-	-	350322	1	350322	1
99	SPROCKET 16T #43 0.625 BORE	-	-	-	-	350319	1	350319	1
101	BEARING CLIP 1.375 OD	-	-	-	-	900321	4	900321	4
102	GUARD SPROCKET	-	-	-	-	350335	1	350335	1
103	SPRING TENSION	-	-	-	-	400217	2	400217	2
104	BOLT CARRAIGE 5/16 - 18 X 1	-	-	-	-	8024040	1	8024040	1
105	BOLT CARRIAGE 1/4-20 X 3/4"	-	-	-	-	8024021	3	8024021	3
106	SCREW SHEET METAL	-	-	-	-	350286	4	350286	4
108	BRACKET SLOT SEEDER	-	-	-	-	350332	1	350332	1
109	SPROCKET WHEEL 16T	-	-	-	-	350318	1	350318	1
110	WASHER 0.906 OD X 0.656 ID	-	-	-	-	350280	4	350280	4
111	CHAIN 35 PITCH	-	-	-	-	350329	1	350329	1
112	COTTER PIN 1/8 - 1"	-	-	-	-	8197031	1	8197031	1
113	ROLL PIN 1/8 - 1 3/4	-	-	-	-	350331	1	350331	1
114	WASHER 5/16 FENDER	-	-	-	-	8172020	4	8172020	4
115	WASHER LOCK 5/16	-	-	-	-	8177011	4	8177011	4
116	SCREWCAP 5/16-18 x 3/4	-	-	-	-	8041026	4	8041026	4
117	WASHER 1/4" SAE	-	-	-	-	8172007	3	8172007	3
118	NUT HEX 10-24	-	-	-	-	8154007	2	8154007	2
119	SCREW 10-24 X 3/4	-	-	-	-	8041026	2	8041026	2

Problem	Possible Cause	Solution
Engine stalls or labors when raking.	Blades set too deep into ground	Raise blades so that they just touch the ground on a level surface.
Abnormal vibration.	Damaged or missing blades. Loose handle bolts. Loose engine bolts	Stop work immediately. Replace any damaged or missing blades. Tighten all loose bolts and nuts.
Engine will not start.	Stop switch off (Honda only). Throttle in off position. Engine not in full choke position. Out of gasoline. Bad or old gasoline. Spark Plug wire disconnected. Dirty air cleaner. Engine oil level too low (Honda only).	Check stop switches, throttle, choke position and gasoline. Connect spark plug wire. Clean or replace air cleaner. Contact a qualified service person.
Engine is locked, will not pull over.	Debris locked against reel, or drive pulleys. Engine problem.	Pull spark plug wire and remove debris. Contact an engine servicing dealer for engine problems.

ENGINE

GENERAL ENGINE SPECIFICATIONS

ENGINE	HORSEPOWER	MODEL NO.	GOVERNED RPM
BRIGGS & STRATTON	5.5	1104020191E1	3700
HONDA	5.5	GX160K1QX	3600

When servicing engine refer to specific manufacturers engine owner's manual. All engine warranty is covered by the specific engine manufacturer. If your engine requires warranty or other repair work contact your local servicing engine dealer. When contacting a dealer for service it is a good idea to have your engine model number available for reference(See table page above). If you can not locate a servicing dealer in your area you can contact the manufacturers national service organization.

To reach:

Briggs & Stratton: 800-233-3723
American Honda: 800-426-7701

UNIT STORAGE

⚠ Never store engine indoors or in enclosed poorly ventilated areas with fuel in tank, where fuel fumes may reach an open flame, spark or pilot light, as on a furnace, water heater, clothes dryer or other gas appliance.

If engine is to be unused for 30 days or more, prepare as follows:

⚠ Remove all gasoline from carburetor and fuel tank to prevent gum deposits from forming on these parts and causing possible malfunction of engine. Drain fuel outdoors, into an approved container, away from open flame. Be sure engine is cool. Do not smoke. Run engine until fuel tank is empty and engine runs out of gasoline.

NOTE: Fuel stabilizer (such as Sta-Bil) is an acceptable alternative in minimizing the formation of fuel gum deposits during storage. Add stabilizer to gasoline in fuel tank or storage container. Always follow mix ratio found on stabilizer container. Run engine at least 10 min. after adding stabilizer to allow it to reach the carburetor.

Engine Service and Warranty
 Contact your nearest engine manufacturer's authorized servicing dealer. (See page 7)

Serial Plate Record your machine model, serial number and date-of-purchase and where purchased



BILLY GOAT INDUSTRIES, INC.

1803 S. Jefferson
 Lee's Summit,
 MO 64062 / USA
 Tel (816) 524-9666
 Fax (816) 524-6983



101 dB

Model	Serial No.
Unit(Weight)	Engine Power
<input style="width: 40px;" type="text"/> lbs. <input style="width: 40px;" type="text"/> kg <input style="width: 40px;" type="text"/> kW <input style="width: 40px;" type="text"/> rpm	

Purchase Date _____ **Purchased from** _____

WARRANTY PROCEDURE

Should a Billy Goat Machine fail due to a defect in material and/or workmanship, the owner should make a warranty claim as follows:

- The Machine must be taken to the dealer from whom it was purchased or to an authorized Servicing Billy Goat Dealer.
- The owner must present the remaining half of the Warranty Registration Card, or, if this is not available, the invoice or receipt.
- The Warranty Claim will be completed by the authorized Billy Goat Dealer and submitted to their respective Billy Goat Distributor for their territory. Attention: Service Manager. Any parts replaced under warranty must be tagged and retained for 90 days.
- The distributor service manager will sign off on the claim and submit it to Billy Goat for consideration.
- The Technical Service Department at Billy Goat will study the claim and may request parts to be returned for examination. Billy Goat will notify their conclusions to the distributor service manager from whom the claim was received.
- The decision by the Quality / Service department at Billy Goat to approve or reject a Warranty claim is final and binding.

Note: To process a Warranty Claim, it is necessary to quote the Model & Serial Number which are printed on the Billy Goat Serial Plate (See owner's manual).



BILLY GOAT INDUSTRIES INC.
 1803 S.W. JEFFERSON / LEE'S SUMMIT, MO 64082-2312 / USA
 PHONE: 816-524-9666 FAX: 816-524-6983 www.billygoat.com