

*Thank You for Selecting*  
**The Powerful QUIET BLOW® BLOWER**

# Operator Owner's Manual

*Push Model*  
**QB1601**

*Self Propelled Model*  
**QB1601SP**

**2 ACCESSORIES**

**GUST ADJUSTER KIT**  
**P/N 400685** Increases blowing distance and blowing control.

**DEFLECTOR REMOTE KIT**  
**P/N 400686** Adds operator remote control for quickly changing between side and forward direction blowing. (Standard on Self Propelled models).

**3 Specifications**

	QB1601	QB1601SP
Engine: HP(kW)	16 H.P. (11.93 kW)	16 H.P. (11.93 kW)
Engine: Type	B & S VANGUARD - TWIN OHV	B & S VANGUARD - TWIN OHV
Engine: Fuel cap.	9 qt. (8.52 L)	9 qt. (8.52 L)
Engine: Oil Cap.	1.75 qt. (1.66 L)	1.75 qt. (1.66 L)
Weight: Unit	234# (106.1 kg)	274# (124.3 kg)
Weight: Shipping	268# (121.6 kg)	322# (146.1 kg)
Engine Weight: (kg.)	79# (35.8 kg)	79 # (35.8 kg)
 <i>UNIT SIZE:</i>	 OVERALL LENGTH: 55"(1.4m) OVERALL WIDTH 35" (0.89m) OVERALL HEIGHT 44.5" (1.13m)	

5



# IN THE INTEREST OF SAFETY

**BEFORE STARTING ENGINE, READ AND UNDERSTAND THE "ENTIRE OPERATOR'S MANUAL & ENGINE MANUAL."**

**THIS SYMBOL MEANS WARNING OR CAUTION. DEATH, PERSONAL INJURY AND/OR PROPERTY DAMAGE MAY OCCUR UNLESS INSTRUCTIONS ARE FOLLOWED CAREFULLY.**



**WARNING:** The Engine Exhaust from this product contains chemicals known to the State of California to cause cancer, birth defects or other reproductive harm.

## WARNING: DO NOT

1. **DO NOT** run engine in an enclosed area. Exhaust gases contain carbon monoxide, an odorless and deadly poison.
2. **DO NOT** place hands or feet near moving or rotating parts.
3. **DO NOT** store, spill or use gasoline near an open flame, or devices such as a stove, furnace, or water heater which use a pilot light or devices which can create a spark.
4. **DO NOT** refuel indoors where area is not well ventilated. Outdoor refueling is recommended.
5. **DO NOT** fill fuel tank while engine is running. Allow engine to cool for 2 minutes before refueling. Store fuel in approved safety containers.
6. **DO NOT** remove fuel tank cap while engine is running.
7. **DO NOT** operate engine when smell of gasoline is present or other explosive conditions exist.
8. **DO NOT** operate engine if gasoline is spilled. Move machine away from the spill and avoid creating any ignition until the gasoline has evaporated.
9. **DO NOT** transport unit with fuel in tank.
10. **DO NOT** smoke when filling fuel tank.
11. **DO NOT** choke carburetor to stop engine. Whenever possible, gradually reduce engine speed before stopping.
12. **DO NOT** run engine at excessive speeds. This may result in injury & /or damage to unit.

13. **DO NOT** tamper with governor springs, governor links or other parts which may change the governed engine speed.

14. **DO NOT** tamper with the engine speed selected by the engine manufacturer.

15. **DO NOT** check for spark with spark plug or spark plug wire removed. Use an approved tester.

16. **DO NOT** crank engine with spark plug removed. If engine is flooded, place throttle in "FAST" position and crank until engine starts.

17. **DO NOT** strike flywheel with a hard object or metal tool as this may cause flywheel to shatter in operation. Use proper tools to service engine.

18. **DO NOT** operate engine without a muffler. Inspect periodically and replace, if necessary. If engine is equipped with muffler deflector, inspect periodically and replace, if necessary, with correct deflector.

19. **DO NOT** operate engine with an accumulation of grass, leaves, dirt or other combustible material in the muffler area.

20. **DO NOT** use this engine on any forest covered, brush covered, or grass covered unimproved land unless a spark arrester is installed on the muffler. The arrester must be maintained in effective working order by the operator. In the State of California the above is required by law (Section 4442 of the California Public Resources Code). Other states may have similar laws. Federal laws apply on federal lands.

21. **DO NOT** touch hot muffler, cylinder, or fins because contact may cause burns.

22. **DO NOT** run engine without air cleaner or air cleaner cover.

23. **DO NOT** operate during excessive vibration!

24. **DO NOT** leave machine unattended while in operation.

25. **DO NOT** park machine on a steep grade or slope.

## WARNING: DO

1. **ALWAYS DO** remove the wire from the spark plug when servicing the engine or equipment TO PREVENT ACCIDENTAL STARTING.
2. **DO** keep cylinder fins and governor parts free of grass and other debris which can affect engine speed.
3. **DO** pull starter cord slowly until resistance is felt. Then pull cord rapidly to avoid kickback and prevent hand or arm injury.
4. **DO** examine muffler periodically to be sure it is functioning effectively. A worn or leaking muffler should be repaired or replaced as necessary.
5. **DO** use fresh gasoline. Stale fuel can gum carburetor and cause leakage.
6. **DO** check fuel lines and fittings frequently for cracks or leaks. Replace if necessary
7. **Follow** engine manufacturer operating and maintenance instructions.
8. **Inspect** machine and work area before starting unit.

6

### TABLE OF CONTENTS

SAFETY INSTRUCTIONS	2
PARTS BAG & CONTROLS	3, 4
LABELS	4
GENERAL SAFETY	3
PACKING CHECKLIST	3
ASSEMBLY	3, 5
OPERATION	6, 7
PARTS DRAWING & LIST	8 - 12
MAINTENANCE	13 - 15
SHOOTING	16
WARRANTY PROCEDURE	16

Part No. 430149

7

### SOUND

Sound tests conducted were in accordance with 2000/14/EEC and were performed on 2/13/2002 under the conditions listed:

**NOTE:** Sound power level listed is the highest value for any model in this manual. Please refer to serial plate on the unit for the sound power level for your model.

Sound level of 99 dBA at operator position



115 dB

GENERAL CONDITION:	Sunny
TEMPERATURE:	43° F (6.1° C)
WIND SPEED:	10 MPH (16.1 kmh)
WIND DIRECTION:	North West
HUMIDITY:	82.2 %
BAROMETRIC PRESSURE:	29.72" Hg (754mm Hg)

Page 2 of 16

8

### VIBRATION

VIBRATION LEVEL 4.0 g

Vibration levels at the operators handles were measured in the vertical, lateral, and longitudinal directions using calibrated vibration test equipment. Tests were performed on 06/24/94 under the conditions listed:

GENERAL CONDITION:	Sunny
TEMPERATURE:	84° F (28.9° C)
WIND SPEED:	5 MPH (8 kmh)
WIND DIRECTION:	North East
HUMIDITY:	71 %
BAROMETRIC PRESSURE:	29.81" Hg (757mm Hg)



Form No. F110802A

# GENERAL SAFETY

*For your safety and the safety of others, these directions should be followed:*

 **Do not operate this machine without first reading owner's manual and engine manufacturer's manual.**

  **Use of Ear Protection is recommended while operating this machine.**

  **Use of Eye and breathing protection is recommended when using this machine, especially in dry and dusty conditions.**

- **DO NOT** place hands or feet inside air intake opening, near exhaust outlet or near any moving parts.
- **DO NOT** start engine without deflector attached to exhaust outlet.

- **DO NOT** direct exhaust outlet toward any bystanders.
- **DO NOT** operate this equipment without first inspecting work area.
- **DO NOT** operate this equipment during excessive vibration.
- **DO NOT** start engine without housing front plate attached.
- **DO NOT** operate this machine on slopes greater than 20%.
- **DO NOT** blow any hot or burning debris, or any toxic or explosive material.
- **DO NOT** allow children to operate this equipment.

# ASSEMBLY



**Read all safety and operating instructions before assembling or starting this unit.**



**PUT OIL IN ENGINE BEFORE STARTING**

Your Billy Goat is shipped from the factory in one carton, completely assembled except for the upper handle assembly, side deflector, front deflector, and panel close.

1. Attach upper handle using pre-mounted hardware on each side (See fig. 6, Page 5).
2. Attach throttle control to upper handle assembly, using pre-mounted screw and lock nut. Assemble stop switch bracket, and throttle to handle using same hardware (See fig. 7, Page 5).

3. Attach throttle cable conduit and stop switch wire to right side of handle in two (2) places using two cable clamps provided in parts bag (See fig. 7, Page 5).
  4. **Self Propelled units only:** Remove nuts securing remote exhaust door control. Use nuts to attach brake and clutch cables as pictured (See fig. 8, Page 5).
  5. **Self Propelled units only:** Attach ends of clutch cable and brake cable in holes provided in bail, and secure bail in pivot holes in upper handle (See fig. 8, Page 5).
  6. **Self Propelled units only:** With remote exhaust door control in rearmost position and exhaust door in closed position thread remote deflector rod into ball joints pre-assembled on door control and exhaust door pivot rod. Adjust to allow necessary range of motion and lock in place using jam nuts provided on rod. (See fig. 8 & 9, Page 5)
  7. Assemble desired deflectors onto side and front of housing exhaust outlet using screws provided on unit. (See fig. 9, Page 5)
- NOTE: The panel front close can be used to completely block off the forward exhaust outlet for jobs where only the side exhaust is needed.

# PACKING CHECKLIST

These items should be included in your carton. If any of these parts are missing, contact your dealer.

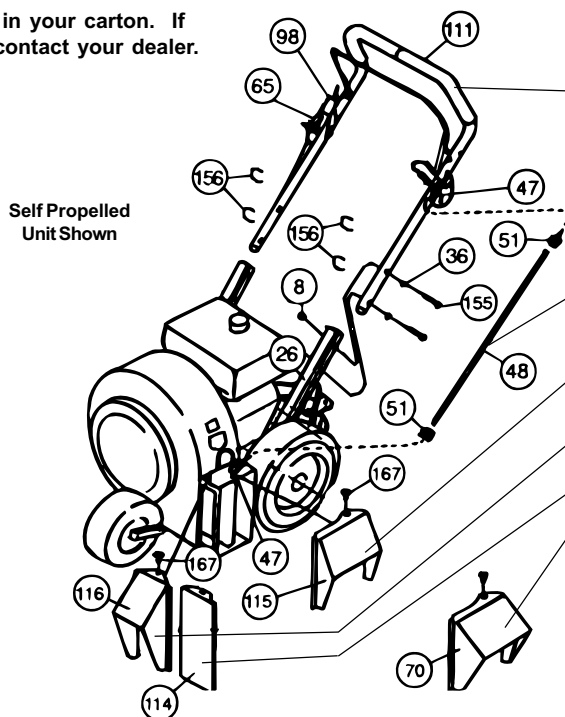

Boxing Checklist	
<input type="checkbox"/>	Handle Upper Assembly 400984 QB1601 — or — 430136 QB1601SP
<input type="checkbox"/>	Rod Diverter Remote 400887 SP ONLY
<input type="checkbox"/>	Deflector Low W.A. 400845
<input type="checkbox"/>	Deflector Front 400680
<input type="checkbox"/>	Panel Front Close 400846
<input type="checkbox"/>	Deflector Side W.A. 400679 SP ONLY
<input type="checkbox"/>	Parts Bag & Literature Assy 400983
<input type="checkbox"/>	Briggs & Stratton Vanguard-Twin 16 HP P/N MS5356 Multi-Lang

Parts Bag & Literature Assy

Engine Manual Per Model

156 Clamp Cable 1" 900813 Qty. 4

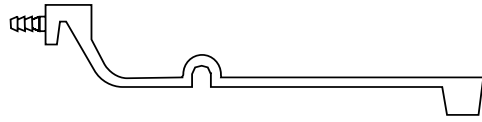

10 Screw Cap 1/4-20X2-1/4" 8041011 Qty. 1

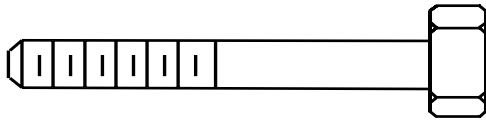

**Owner's Manual**  Check **Owner's Manual 430149**

**Literature QB1601 Accessories**  Check **Literature QB 1601 Accessories 400909**

**Warranty Card**  Check **Warranty Card 400972**

**EU Declaration of Conformity & EU Distributor List**  Check **EU Declaration of Conformity & EU Distributor List 430150**

**Throttle Control**

**Start position**

*Briggs Vanguard Units have a choke type carburetor that is operated using choke lever on side of engine.*

**Stop position**

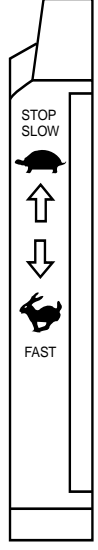

**INSTRUCTION LABELS**

These labels should be included on your Blower. If any of these labels are damaged, replace them before putting this equipment into operation. Item and part numbers are given to help in ordering replacement labels.



Label Do Not Fill While Engine Is Hot Item 175 Part No.400268



Label Danger Keep Hands and Feet Away Item 172 Part No.400424



Label Danger Flying Material Item 173 Part No. 810736



Label Read item No.110 Part No. 890301



Label Ear Eye Breathing Item No.174 Part No. 890254

All Models

SP Models Only



Label Oil Chain Item 100 Part No. 830502



Label Clutch VQ Item 166 Part No. 830503



Label Danger Guards Item 157 Part No. 900327

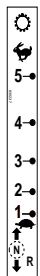

Label Speed Control Item 101 Part No. 830237

**ENGINE LABELS**

**Briggs & Stratton Vanguard 16HP**

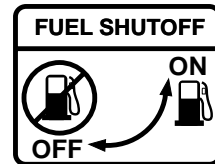
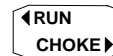

**ENGINE MAINTENANCE**

- 1. CHECK OIL LEVEL 8 HOURS
  - 2. CHECK & CLEAN AIR CLEANER 25 HOURS
  - 3. CHANGE OIL 50 HOURS
  - 4. REPLACE OIL FILTER 100 HOURS
  - 5. CLEAN COOLING FINS 100 HOURS
- See Operating and Maintenance Instructions

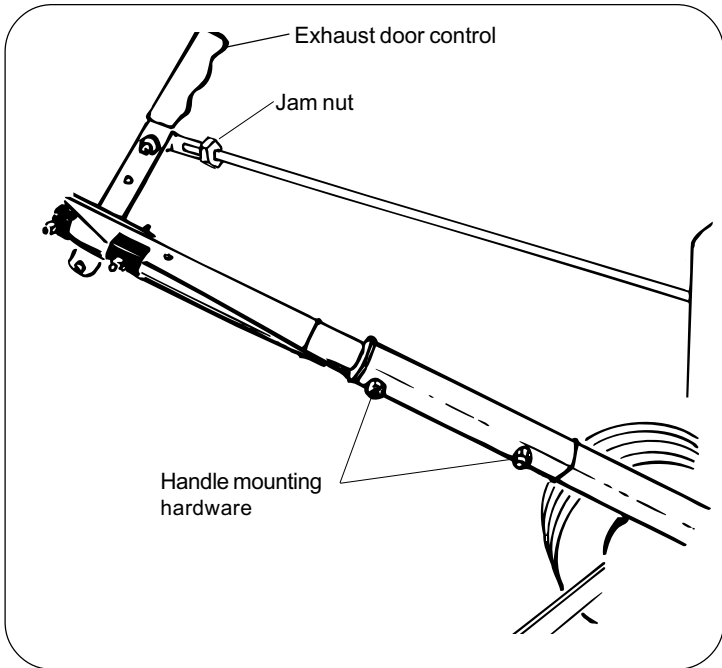

Fig. 6

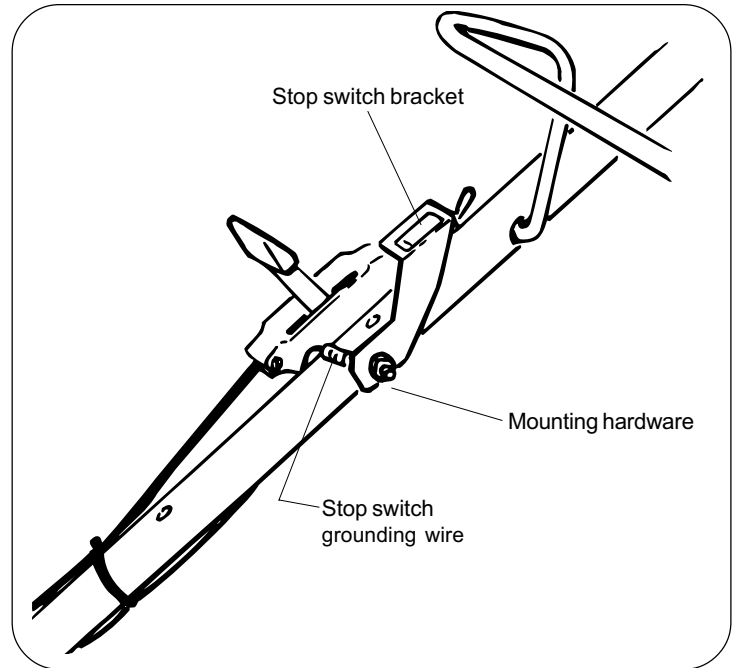

Fig. 7

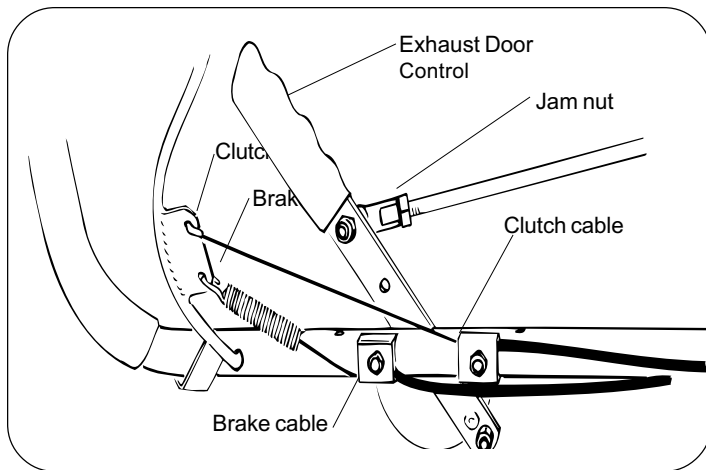

Fig. 8

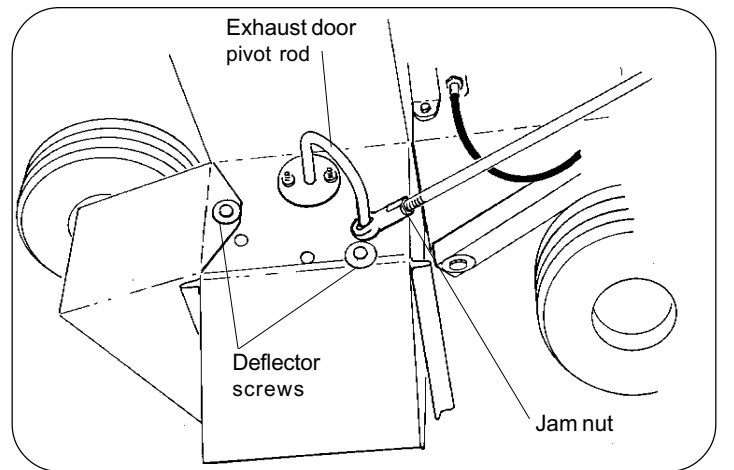

Fig. 9

# OPERATION

**INTENDED USE:** This machine is designed for cleaning outdoor surfaces, where the debris can be effectively blown into a consolidated area for convenient pickup and removal.

Do not operate if excessive vibration occurs. If excessive vibration occurs, shut engine off immediately and check for damaged or worn impeller, loose impeller bolt, loose impeller key, loose engine or lodged foreign objects.

Note: See parts list for proper impeller bolt torque specifications. (See trouble shooting section on page 16).



Like all mechanical tools, reasonable care must be used when operating machine.

**Inspect machine work area and machine before operating. Make sure that all operators of this equipment are trained in general machine use and safety.**



**PUT OIL IN ENGINE BEFORE STARTING**

## 16.1 STARTING



**ENGINE:** See engine manufacturer's instructions for type and amount of oil and gasoline used.

Engine must be level when checking and filling oil and gasoline.

**ENGINE SPEED:** Controlled by throttle lever on the handle. Under normal conditions, operate at minimum throttle to accomplish your current cleaning task.

**STOP SWITCH:** Located on engine for Push models and on upper handle for SP models. Switch must be in "ON" position to start engine.

**FUEL VALVE:** Move fuel valve to "ON" position.

**CHOKE:** Operated with choke lever on side of engine.

**THROTTLE:** Move remote throttle control to fast position. Pull starting rope to start engine.

### IF YOUR UNIT FAILS TO START:

See Troubleshooting on page 16.

## 16.2 BLOWING OPERATION

The diverter rod controls the closing (O) and opening (I) of the exhaust outlet. Adjust diverter rod to side discharge for normal blowing or to forward discharge for blowing along walls, fences or hard-to-reach areas (see Fig. 1).

**Diverter Rod**

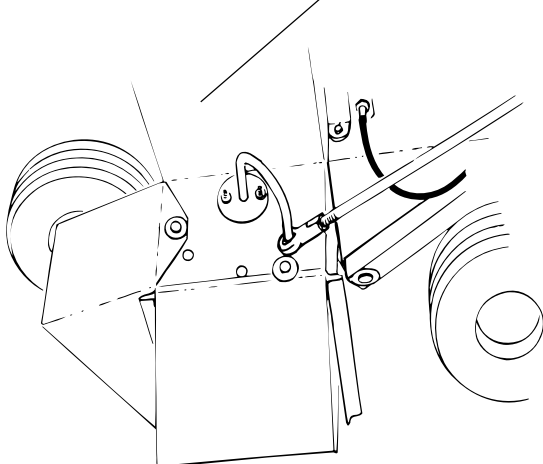

Fig. 1

**OPTIONAL GUST ADJUSTER KIT increases blowing distance and blowing control.** ( can be purchased separately, see page 1 for optional accessories).

**Deflectors adjusted upward increases air volume and blowing distance.**

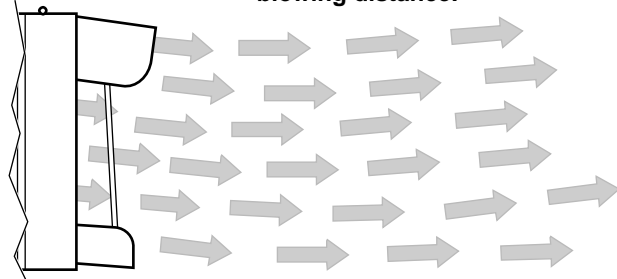

Fig. 2

**Deflectors adjusted downward increases air velocity for cleaning crevices and blowing heavier debris.**

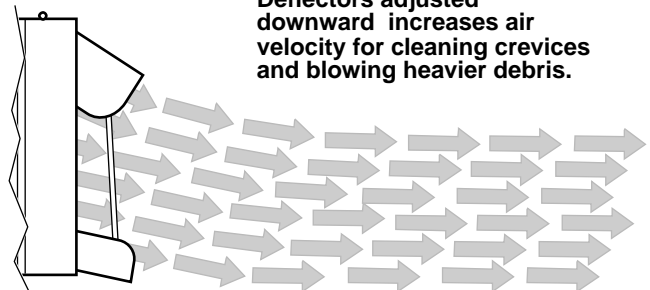

Fig. 3

Debris in the air stream can be blown farther by adjusting the deflectors in a consistent up-and-down motion.

## 16.4

### HANDLING & TRANSPORTING:

Move diverter rod to closed (O) position. Do not lift by hand. Use loading ramps or other mechanical assistance. Secure in place during transport.

## 16.5

### STORAGE

**⚠** Never store engine indoors or in enclosed poorly ventilated areas with fuel in tank, where fuel fumes may reach an open flame, spark or pilot light, as on a furnace, water heater, clothes dryer or other gas appliance.

**If engine is to be unused for 30 days or more, prepare as follows:**

**⚠** Be sure engine is cool. Do not smoke. Remove all gasoline from carburetor and fuel tank to prevent gum deposits from forming on these parts and causing possible malfunction of engine. Drain fuel outdoors, into an approved container, away from open flame. Run engine until fuel tank is empty and engine runs out of gasoline.

**NOTE:** Fuel stabilizer (such as Sta-Bil) is an acceptable alternative in minimizing the formation of fuel gum deposits during storage. Add stabilizer to gasoline in fuel tank or storage container. Always follow mix ratio found on stabilizer container. Run engine at least 10 min. after adding stabilizer to allow it to reach the carburetor.

16.6 PROPULSION self propelled only

**PROPULSION:** QB1601 self-propelled blowers are equipped with 5 forward gears, neutral and reverse. (see TABLE 1 below) With the engine running, and the bail in released position select desired drive gear.(see Fig. 4) Pull bail against handle to automatically release brake and engage drive (see Fig. 5). Smoothly engage the bail.

Use good judgement when operating the self propelled drive. Fifth gear is a fast walking speed and should be used only for moving quickly from place-to-place. Using neutral, on level terrain is advisable when maneuvering in tight areas. This increases operator control, and can prevent bumping into nearby objects.

Do not force-shift gears of transmission. **Shift gears only when drive is disengaged.** To stop machine, release operator's bail. To move unit by hand "freewheeling", requires that the gear shift be in neutral (see Fig. 4), and the operator hold the drive bail against the handle to disengage the parking brake.

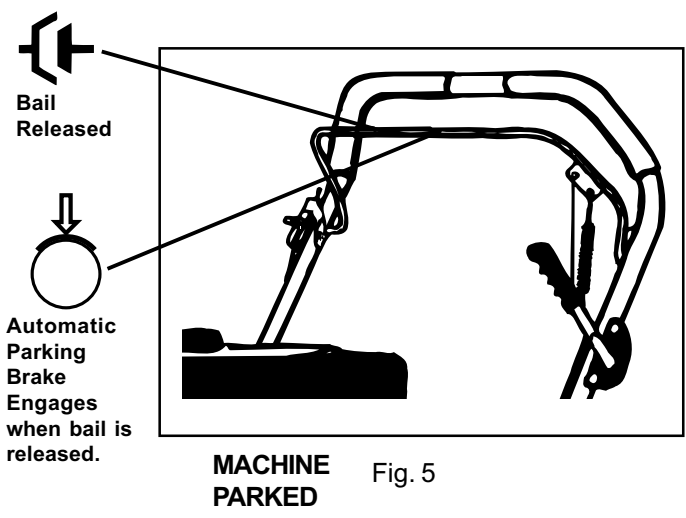

Fig. 5

**When using Reverse - Set Throttle to Idle.**

With operator's bail released, move shift lever past neutral stop, by pulling the shift lever back and moving it to the right, into "Reverse" gear position. Then smoothly pull operator's bail against handle. Release bail to stop (see figure 5).

Gear Shift Shown In Neutral

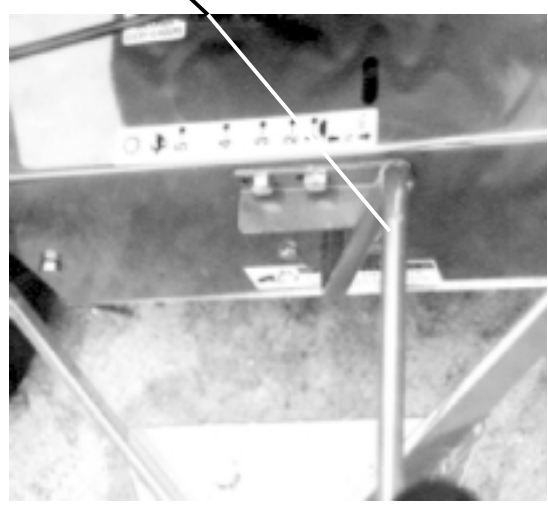
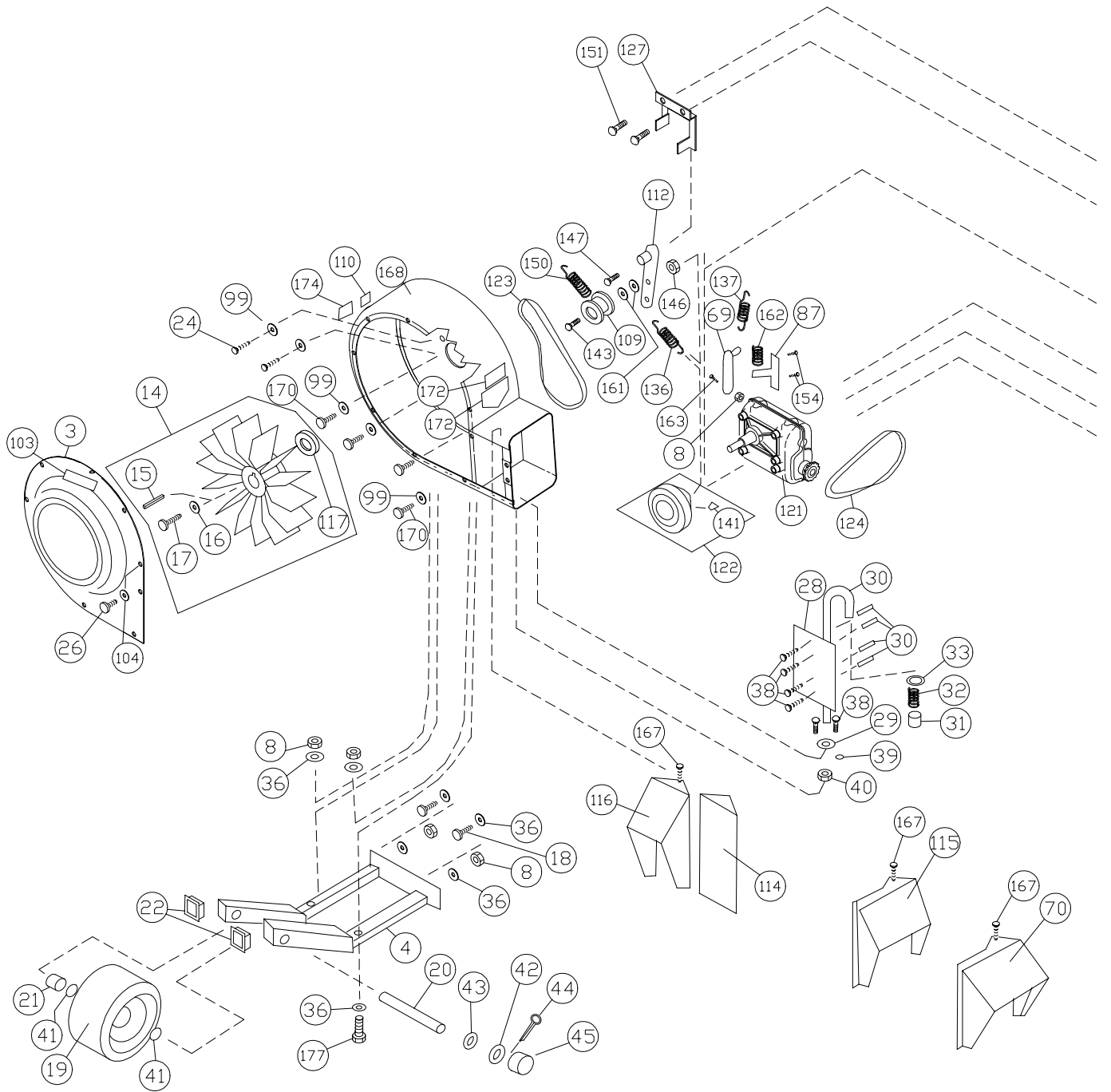

Fig. 4

DRIVE GEAR SELECTION @ (3600 RPM)							
<i>Self Propelled Only</i>							
Position	Rev.	N	1	2	3	4	5
MPH	3.97	0	2.57	3.40	4.46	5.29	6.76
KMH	6.39	0	4.14	5.47	7.19	8.52	10.88

Table 1



**(18) PARTS DRAWING**

**QB1601, QB1601SP**

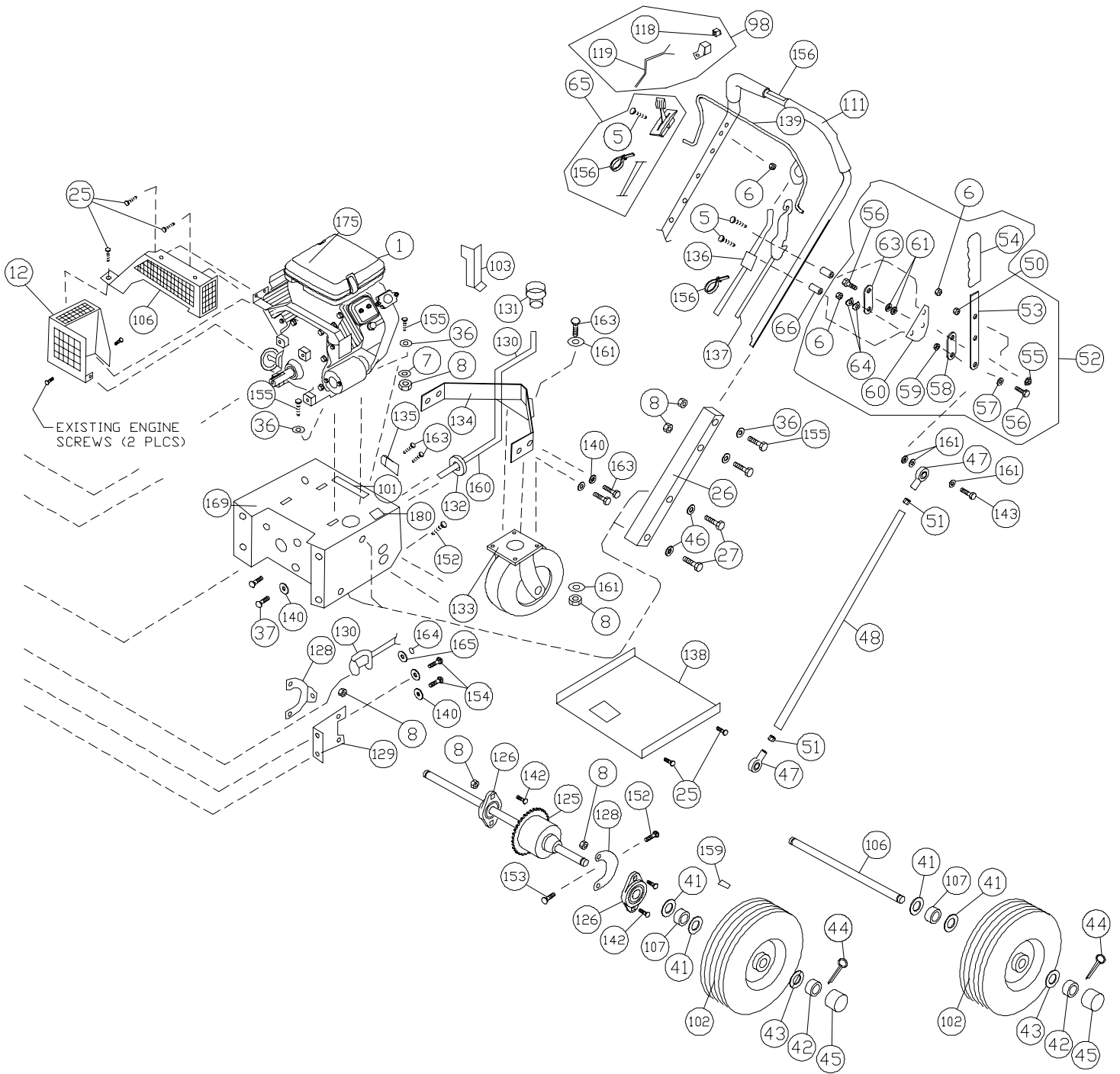

**18 PARTS DRAWING**

**QB1601, QB1601SP**

Item No.	19 PARTS LIST Continued	Description	QB1601	QTY	QB1601SP	QTY
1		ENGINE 16 HP VANGUARD	811057	1	811057	1
2						
3		GRILL SCROLL W. A.	400652	1	400652	1
4		FRAME FRONT WHEEL W.A.	400656	1	400656	1
5		SCREW CAP 1/4-20 x 2-1/4"	*8041011	1	*8041011	3
6		NUT LOCK 1/4-20	*8160001	1	*8160001	6
7		WASHER FLAT 5/16 SAE	*8172008	4	*8172008	7
8		NUT LOCK 5/16-18	*8160002	16	*8160002	28
9		CONTROL THROTTLE	850270	1	850270	1
10						
11						
12		GUARD MUFFLER	811058	1	811058	1
13						
14		IMPELLER ASSY QB1601	400720	1	430107	1
15		KEY 1/4 SQ X 2.25	9201123	1	9201123	1
16		WASHER LOCK 3/8 TWISTED TOOTH.	400502	1	400502	1
17		SCREW CAP 3/8-24 X 1 1/4 GR 8 (TORQ 50 ft.lbs.[68 Nm] )	400946	1	-	-
		SCREW CAP 3/8-24 x 2 1/4 GR. 8(TORQ. 50 ft.lbs.[68 Nm] )	-	-	810932	1
18		SCREW CAP 5/16-18 X 1"	*8041028	4	*8041028	4
19		WHEEL FRONT	400295	1	400295	1
20		AXLE FRONT	400730	1	400730	1
21		TUBE SPACER QB 1600	400733	1	400733	1
22		CAP - PLUG 1.25 SQ	400640	2	400640	2
23						
24		SCREW CAP 3/8-16 X 1 3/4	*8041053	2	-	-
		SCREW CAP 3/8-16 x 2"	-	-	*8041054	2
25		SCREW SHEET METAL 1/4 AB X 3/4	*8122082	11	*8122082	17
26		HANDLE LOWER W.A.	400735	2	400735	2
27		SCREW CAP 5/16-18 X 2	*8041032	4	*8041032	2
28		DEFECTOR EXHAUST	400677	1	400677	1
29		WASHER WEAR PLATE	400684	1	400684	1
30		ROD DIVERTER QB1600	400697	1	400697	1
31		SPACER	400330	1	-	-
32		SPRING COMPRESSION	400332	1	-	-
33		RING GRIP	400340	1	400340	1
36		WASHER FLAT CUT 5/16	*8171003	20	*8171003	17
37		SCREW CAP 5/16-18 X 3/4	-	-	*8041026	4
38		SCREW MACH #10 - 24 X 5/8 HEX WF	*8059135	6	*8059135	6
39		NUT LOCK # 10-24	*8164005	8	*8164005	8
40		WASHER FLAT CUT 3/8	*8171004	2	*8171004	1
41		WASHER 3/4 SAE	*8172015	6	*8172015	4
42		WASHER HUB CAP	850237	4	850237	4
43		WASHER (0.765 X 1.25 OD X 0.06)	850238	4	850238	4
44		PIN COTTER 1/8 X1	*8197031	4	*8197031	4
45		CAP HUB	900486	4	900486	4
46		WASHER FENDER	*8172020	4	*8172020	4
47		ROD END BALL JOINT 3/8-24	-	-	400886	2
48		ROD DIVERTER REMOTE	-	-	400887	2
49						
50		NUT LOCK 3/8 - 16	-	-	*8160003	1
51		NUT JAM 3/8-24	-	-	*8149003	2
52		LEVER FRICTION ASSY	-	-	400875	1
53		BAR LEVER REMOTE	-	-	400839	1
54		GRIP HANDLE	-	-	850190	1
55		NUT 1/4-20 WASHER FACE	-	-	900455	1
56		SCREW CAP 1/4-20 x 1"	-	-	*8041006	2
57		WASHER LOCK 1/4 EXT.	-	-	*8181007	1
58		PLATE FRICTION LIFT	-	-	850191	1
59		NUT JAM 1/4-20	-	-	*8150001	1
60		PLATE QUAD LIFT	-	-	850192	1
61		WASHER 1/4 FLAT CUT	-	-	*8171002	2
62		BALL 1/4"	-	-	850194	1
63		PLATE CLAMP LIFT	-	-	850193	1
64		WASHER 1/4" BELLVILLE	-	-	850207	2
65		THROTTLE CONTROL ASSY (Incl. items 5,6,9,156 )	810135	1	810135	1
66		SPACER	-	-	850198	2
67		BAR MOUNT BRAKE	-	-	430112	1
68						
69		BAR MOUNT SPRING	-	-	430111	1
70		DEFLECTOR SIDE WA	-	-	400679	1
98		SWITCH ENGINE ASSY	430140	1	430140	1
99		WASHER LOCK 5/16 TWISTED TOOTH	800177	6	800177	6

Item No.	19 PARTS LIST Continued	Description	QB1601	QTY	QB1601SP	QTY
100		LABEL OIL CHAIN	-	-	830502	1
101		LABEL SHIFT	-	-	830237	1
102		WHEEL TIRE ASSY 16"	850147	2	-	-
		WHEEL & TIRE ASSY 16" SP	-	-	850229	2
103		LABEL 1601	430114	1	430114	1
104		WASHER LOCK 1/4 SPLIT	8177010	12	8177010	15
105		GUARD CLUTCH QB1601SP	-	-	430145	1
106		GUARD MANIFOLD	811059	1	811059	1
107		SPACER WHEEL	800421	6	800421	2
108		AXLE REAR PUSH	400770	1	-	-
109		PULLEY IDLER	-	-	800260	1
110		LABEL READ OWNERS MANUAL	890301	1	890301	1
111		HANDLE UPPER ASSY W/GRIP	400984	1	430136	1
112		IDLER PIVOT WA	-	-	430157	1
113		PARTS BAG QB 1601	400776	1	-	-
114		PANEL FRONT CLOSE	400846	1	400846	1
115		DEFLECTOR LOW W.A.	400845	1	400845	1
116		DEFLECTOR FRONT	400680	1	400680	1
117		SPACER ENGINE	-	-	830112	1
118		SWITCH ROCKER	500281	1	500281	1
119		HARNES ASSY SV	890442	1	890442	1
120						
121		TRANSMISSION 5 SPD/1 REV. W/BRAKE	-	-	830179	1
122		PULLEY 7" DIA.	-	-	800251	1
123		BELT 4L x 34" O.L.	-	-	830223	1
124		CHAIN #40 x 46 PITCH HEAVY DUTY	-	-	430124	1
125		DIFFERENTIAL ASSY 28T	-	-	430103	1
126		BEARING & FLANGE ASSY 0.75"	-	-	850232	3
127		BELT FINGER WA QB1601SP	-	-	430152	1
128		PLATE TENSION CHAIN W/INSERT	-	-	430122	2
129		PLATE MOUNT BEARING	-	-	430110	1
130		ROD SHIFT WA QB1601SP	-	-	430129	1
131						
132		PLATE BUSHING SHIFTER	-	-	430123	1
133		CASTER ASSY 8" PNEU.	-	-	400731	1
134		CASTER BRACKET WA QB16	-	-	430132	1
135		PLATE NEUTRAL STOP	-	-	430127	1
136		CABLE ASSY CLUTCH QB1601SP	-	-	430125	1
137		CABLE ASSY BRAKE QB1601SP	-	-	430126	1
138		PLATE GUARD DRIVE	-	-	430135	1
139		BAIL DRIVE WA QB1601SP	-	-	430137	1
140		WASHER LOCK 5/16 SPLIT	-	-	*8177011	10
141		KEY HI-PRO 3/16 x 3/4	-	-	850234	1
142		BOLT CARRIAGE 5/16-18 x 1"	-	-	*8024040	6
143		SCREW CAP 3/8-16 x 1 1/2	-	-	*8041052	2
144		WASHER 3/8 SAE	-	-	*8172009	1
145		NUT LOCK 3/8-16 THIN HT.	-	-	*8161042	1
146						
147		BOLT SHOULDER 1/2" x 1"	-	-	500114	1
148						
149						
150		SPRING	-	-	800242	1
151		SCREW CAP 5/16-24 x 3/4 GR. 5	-	-	*8042026	2
152		SCREW CAP 5/16-18 x 2 1/2	-	-	*8041033	2
153		NUT JAM 5/16-18	-	-	*8142002	2
154		SCREW SELF TAP 5/16 x 3/4	-	-	8123128	4
155		SCREW CAP 5/16-18 X 1 3/4	*8041031	8	*8041031	7
156		CLAMP CABLE PLASTIC 1"	900813	2	900813	4
157		LABEL DANGER GUARDS	-	-	900327	1
158		WASHER 3/4 FLAT CUT	-	-	*8171009	4
159		KEY 3/16 SQ. x 2 1/8	-	-	9201087	2
160		SCREW CAP 1/4-20 x 1"	-	-	*8041006	6
161		WASHER 3/8 SAE	-	-	*8172009	13
162		SPRING TENSION	-	-	400217	1
163		SCREW CAP 5/16-18 x 3/4"	-	-	*8041026	7
164		SCREW CAP 1/4-28 x 1/2 GR. 5	-	-	850408	1
165		WASHER 1/4 SAE	-	-	*8172007	1
166		LABEL CLUTCH	-	-	830503	1
167		SCREW CAP WASHER FACE SEM 1/4 - 20 X 3/4	900450	2	900450	2
168		HSG ASSY	400914	1	400914	1
169		BASE ENGINE ASSY (PUSH MODEL)	430113	1	-	-
		BASE ENGINE ASSY W/LABELS (SP MODEL)	-	-	430105	1

\* Denotes standard hardware item that may be purchased locally.

	19	PARTS LIST	Item Continued No.	Description	QB1601	QTY	QB1601SP	QTY
170				SCREW CAP 5/16-18 x 1" GR. 5	400912	4	400912	4
171								
172				LABEL WARNING OPEI	400424	1	400424	1
173				LABEL DANGER FLYING MATERIAL	810736	1	810736	1
174				LABEL EAR EYE BREATHING	890254	1	890254	1
175				LABEL DO NOT FILL WHEN ENGINE IS HOT	400268	1	400268	1
176				SCREW MACH. #10-24 x 1 1/2	*8059145	1	*8059145	1
177								
178				WASHER LOCK 1/4 SPLIT	-	-	*8041029	2



**Clear** intake screens on housing and engine throughout use.

**Inspect** machine for loose bolts before starting engine.

**Lubrication:** Using S.A.E. 30 weight oil or equivalent. See maintenance schedule.



**Chain:** See SP section below.

**Lower Control Ends:** Oil moving parts, such as bail, and deflector door pivots.

**Grease:** Front wheel, and Caster(SP only).

**Tire air pressure:** Check at regular intervals & maintain:

Low tire pressure will make unit hard to push and turn.

Front tire at **30 psi**. (21.1 kPa).

Rear push 16" tires at **30 psi**. (21.1 kPa).

Rear SP 16" tires at **35 psi**. (24.6 kPa).

Rear caster tire (SP only) at **30 psi** (21.1 kPa)

## 17.3

## DRIVE

**Chains and Belts are normal replaceable wear items. A new chain should not be used on worn sprockets. Sprockets should be inspected and replaced when worn.**

## MAINTENANCE- SP MODELS ONLY

**Brake Adjustment:** As parking brake wears, the brake discs may eventually require adjustment. To adjust, remove bottom guard from engine base and tighten brake adjusting nut on transmission. Adjust cable nut as required. Unit must free-wheel in neutral with clutch engaged and brake off.

**DO NOT OVER ADJUST.**

**Chain Adjustment:** (See fig. 11)

1. Remove spark plug wire.
2. Remove bottom drive guard.
3. Inspect chain and sprockets for wear, lubrication and tension. Replace if badly worn or damaged. Skip to **CHAIN REPLACEMENT**
4. Check chain tension. There should be no more than 0.25" total movement when chain is flexed from top to bottom.
5. To increase chain tension, loosen, do not remove, the bolts that hold the bearings in place on each side and in the center of the differential.
6. Loosen, do not remove, the Jam nut that locks the bolt into the chain tensioner on each side of the differential.
7. With the bolts loose, equally tighten the chain tensioner bolt on both the left and right side of the differential.
8. Adjust in small increments, checking chain alignment, tension and axle squareness between steps. Roll wheels to check that there are no excessively tight areas in the chain. Repeat adjustment steps if necessary. A slightly loose chain is better than an over tightened one.
9. With chain properly adjusted securely tighten the jam nuts, and bearing mount bolts.
10. Reinstall drive guard.
11. Reconnect spark plug wire.

**Chain Lubrication:** With machine not running, oil chain using general purpose S.A.E. 30 weight oil every 25 hours or as needed. Chain oiling hole is located on operator's left at rear of engine base. Note: Be sure that entire length of chain is properly oiled. Oiling only a few positions in the chain rotation will not properly oil the chain.

**Belt Adjustment:** As V-belt wears, adjustments may be required to maintain proper clutch engagement. Adjust by tightening or by loosening clutch cable adjusting nut as required, located on operators left near the face of the engine (See fig. 10). When replacing belt, see **BELT REPLACEMENT. DO NOT OVER ADJUST.**

**Belt Replacement:**

1. Remove impeller, follow impeller removal instructions on page 13.
2. Remove six screws securing blower housing.
3. Inspect for worn or damaged pulleys. Replace if necessary.
4. Replace worn belt.
5. Replace housing. Note: Be sure to replace lock clip on upper bolts in exact manner that it was originally installed.
6. Replace impeller, refer to impeller removal instructions on page 13.
7. It may be necessary to adjust the belt engagement. See **Belt Adjustment.**

**Chain Replacement:** (See fig. 11)

1. Remove spark plug wire.
2. Remove bottom drive guard.
3. Inspect sprockets for wear. Replace if badly worn or damaged.
4. Release chain tension. See **Chain Adjustment.**
5. Remove operators right and center axle bearings.
6. Remove old chain by sliding over the axle and out the hole that the right axle bearing was mounted in.
7. Install new chain in the reverse order of removal.
8. Set chain tension. See **Chain Adjustment.**
9. Replace bottom drive guard.
10. Replace spark plug wire.



Fig. 10

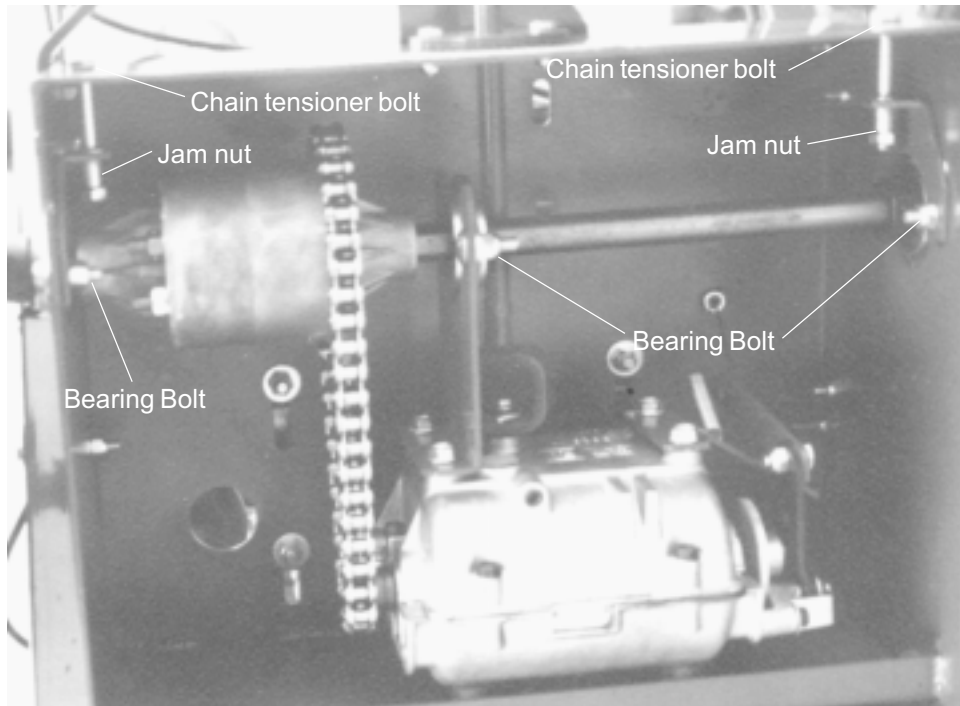

Fig. 11

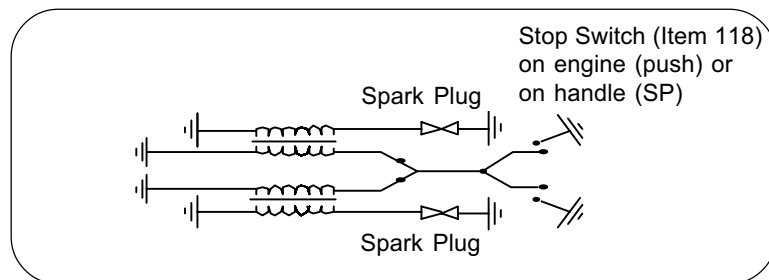



Fig. 12

**20 TROUBLESHOOTING** *Before Requesting Service Review These Suggestions*

Problem	Possible Cause	Solution
Poor air performance	Air intake or exhaust clogged.	Clear clog.
Machine is difficult to maneuver.	Low tire air pressure.	Inflate front and rear tires to correct pressure. (See tire pressures on page 14.)
Abnormal vibration	Loose or out of balance impeller or loose engine.	Check impeller and replace if required. Check Engine.
Engine will not start	Stop switches off. Choke lever not in on position. Out of gasoline. Bad or old gasoline. Spark Plug wire disconnected. Dirty air cleaner.	Check switches, choke, gasoline and oil. Check for spark with an approved tester. Clean or replace air cleaner. Contact qualified service person.
Engine is locked, will not pull over.	Engine problem.	Contact your nearest engine manufacturers servicing dealer.
<b>Self Propelled Units Only</b>		
No self-propelling	Transmission not in gear. Operator's bail not engaging belt or out of adjustment. Worn out or broken chain. Broken or mispositioned belt.	Check transmission gear selection. Check clutch cable adjustment, belt and chain (See page 14).
Self propelled drive will not release	Sticking belt idler arm. Belt fingers bent or broken.	Check idler. Idler arm mounting screw may be too tight or too loose. Check belt guide. Replace if broken.
Noisy or broken chain	No chain lubrication. Chain out of alignment or over tensioned.	See Chain Adjustments on page 14.

**22.1 Engine Service and Warranty**  
**Contact your nearest engine manufacturer's authorized servicing dealer.**

**21 Serial Plate** *Record your machine model, serial number and date-of-purchase and where purchased*



**BILLY GOAT INDUSTRIES, INC.**

1803 S. Jefferson  
 P.O. Box 308  
 Lee's Summit,  
 MO 64063 / USA  
 Tel (816) 524-9666  
 Fax (816) 524-6983



115 dB

Model	Serial No.
Unit (Weight)	Engine Power
<input type="text"/> lbs. <input type="text"/> kg	<input type="text"/> kW <input type="text"/> rpm

**Purchase Date** \_\_\_\_\_ **Purchased from** \_\_\_\_\_

**22 WARRANTY PROCEDURE**

Please fill in the WARRANTY CARD and send the upper part to Billy Goat. The WARRANTY terms are stated on the lower part which remains with the user. Whenever a Billy Goat Machine is faulty due to a defect in material and / or workmanship, the owner should make a warranty claim as follows:

- The Machine should be taken to the dealer from whom it was purchased or to an authorized Billy Goat dealer.
- The owner should present the remaining half of the Warranty Registration Card, or, if this is not available, the invoice or receipt.
- The Warranty Claim will be filled in by the authorized Billy Goat Dealer, who will send it with the faulty part to Billy Goat headquarters.
- The Quality / Service department at Billy Goat headquarters will study the claim and parts and will notify their conclusions.
- The decision by the Quality / Service department at Billy Goat headquarters to approve or reject a Warranty claim is final and binding.

*Note:* To process a Warranty Claim, it is necessary to quote the Model & Serial number who are printed on the Billy Goat Serial Plate.

**BILLY GOAT** **BILLY GOAT INDUSTRIES INC.**  
 P.O. BOX 308, 1803 S JEFFERSON LEE'S SUMMIT, MO. 64082-2312 / USA  
 PHONE: 816-524-9666 FAX: 816-524-6983 www.billygoat.com